

Check Valves & Pressure Regulators



Assembling Upchurch Scientific® Back Pressure Regulator cartridges in Oak Harbor, WA.



Dear Customer

We are pleased to present our 2011/2012 catalog, which includes Innovadyne™, Ismatec®, Isolation Technologies™, Rheodyne®, Systec®, and Upchurch Scientific® products. In this catalog, you will find all the critical fluidic products and high-quality components you've come to expect from IDEX Health & Science.

This catalog has a new 'look and feel', with a new organization to all of our products. Now, you will be able to find all of our fittings in one chapter, with separate chapters for products like tubing, valves, pumps, etc. And, as always, we have many new products – including some very innovative UHPLC fittings and accessories – scattered throughout the catalog that we hope will prove useful to you.

We appreciate your business and continued loyalty to our family of products and services and thank you for trusting IDEX Health & Science with your liquid handling needs. Your feedback is valuable, so please let us know if there are ways we can be of greater service.



Joe Stupfel

VP Marketing & Research, Development & Engineering
IDEX Health & Science LLC

IDEX Health & Science Contact Information

NORTH / SOUTH AMERICA

IDEX Health & Science LLC

619 Oak Street
Oak Harbor, WA 98277 USA
Tel: +1 800 426 0191
Fax: +1 800 359 3460
Fax: +1 360 679 3830
E-mail: CustomerService.hs@idexcorp.com

EUROPE

IDEX Health & Science GmbH

Futtererstrasse 16
97877 Wertheim
Germany
Tel: +49 (0) 1801 808 800
Fax: +49 (0) 9377 1388
E-mail: CustomerService.hseurope@idexcorp.com

ASIA

IDEX Trading (Shanghai) Co. Ltd

Room 1701A
CBD International Plaza
No. 16 Yong An Dong Li
Beijing, China 100022
Tel: +86 10 6566 9090
Fax: +86 10 6567 5152
E-mail: CustomerService.hsasia@idexcorp.com

IDEX Asia Pacific Pte Ltd

63 Hillview Avenue #07-08
Lam Soon Industrial Building
Singapore 669569
Tel: +65 6314 6145
Fax: +65 6764 4020
E-mail: CustomerService.hsasia@idexcorp.com

IDEX India Pvt Ltd

205, Matharu Arcade
Plot No. 32 Subhash Road
Vile Parle (East)
Mumbai – 400 057 India
Tel: +91 22 66 78 00 50
Fax: +91 22 66 78 00 55
E-mail: CustomerService.hsasia@idexcorp.com

IDEX Health & Science

6F Sanseido Bldg.
2-4 Kojimachi, Chiyoda-ku,
Tokyo 102-0083, Japan
Tel: +81 3 3263 5390
Fax: +81 3 3511 5890
E-mail: CustomerService.hsasia@idexcorp.com

How to Order

Direct from IDEX Health & Science

For North America orders:

Tel: +1 800 426 0191 ▶ +1 360 679 2528
Fax: +1 800 359 3460 ▶ +1 360 679 3830
E-mail: CustomerService.hs@idexcorp.com

For Europe orders:

Tel: +49 (0) 1801 808 800
Fax: +49 (0) 9377 1388
E-mail: CustomerService.hseurope@idexcorp.com

For Asia orders:

E-mail: CustomerService.hsasia@idexcorp.com

NORTH ASIA

Tel: +86 10 6566 9090
Fax: +86 10 6567 5152

SOUTH AND SOUTHEAST ASIA

Tel: +91 22 66 78 00 50
Fax: +91 22 66 78 00 55

JAPAN

Tel: +81 3 3263 5390
Fax: +81 3 3511 5890

For Online orders:

Web: www.idex-hs.com

Please include the following information with your order: Purchase Order Number, Contact Name, Shipping and Billing Address, Telephone Number, Product Number(s) and Quantity(ies). If you are a Purchasing Agent, please include the name of the person for whom the products are ordered.

For your information, our Federal Taxpayer Identification number is 01-0736657.

Order Processing/Shipping

Orders process within one business day and ship within two business days. Requests for earlier shipments can be made — please contact IDEX Health & Science for more details.

All shipments are FCA unless otherwise noted. Shipping charges will be prepaid and added to the invoice. Or, if requested, we will charge your carrier account number.

Terms



Terms of payment are net 30 days. Mastercard®, Visa® and American Express® are accepted.

There is no minimum order. Customers are responsible for C.O.D. charges if they elect this payment method. Terms and prices are subject to change without notice. Visit www.idex-hs.com for complete Terms & Conditions.

Return of Materials

Returns must be authorized in advance. Please contact us within 30 days of purchase for your Returns Material Authorization (RMA) Number. A restocking fee may apply.

Direct from our Global Distribution Network

The IDEX Health & Science brands represented in this catalog (Innovadyne™, Ismatec®, Isolation Technologies™, Rheodyne®, Systec®, and Upchurch Scientific®) have established relationships with a large, global network of Distributors, many of whom can offer the product support and assistance that we cannot, including:

- ▶ Carrying local inventory of commonly-ordered items
- ▶ Understanding YOUR working environment and requirements
- ▶ Providing technical application assistance
- ▶ Answering questions regarding new and existing products
- ▶ Complete availability during your time zone business hours
- ▶ Personal visits as required
- ▶ Access to complementary product lines to provide a “one-stop shopping” experience

We have come to rely on our authorized Distributors to provide value-added service to end-users of our products. So, while we are happy to take your order directly, we encourage you to contact your local Distributor — we feel confident it will be a positive experience!

How to Find A Local Distributor

For a complete distributor listing please visit www.idex-hs.com/distributors or email:

US: CustomerService.hs@idexcorp.com
Europe: CustomerService.hseurope@idexcorp.com
Asia: CustomerService.hsasia@idexcorp.com

Our customer service team will help you contact a distributor in your area.

Return of Materials

Product purchased through a Distributor must be returned directly to that Distributor. Please contact them for Return Material Authorization procedures.

Visit Us At  WWW.IDEX-HS.COM

The products in this catalog are intended for use with analytical, biotechnology and diagnostic equipment and accessories. THE MANUFACTURERS OF THE PRODUCTS IN THIS CATALOG SHALL HAVE NO LIABILITY WHATSOEVER DUE TO ANY MISUSE OF THEIR PRODUCTS. Of course, the safe use of our products depends on our customers, since it is you who select and control the protective gear and safety procedures used, as well as the pressures, temperatures, solvents, samples, ventilation, and other variables. Product and material performance ratings are provided as guides only. Individual field tests should be performed by customers to determine safe operating parameters given your particular procedures and use.

IDEX Health & Science facilities are certified ISO 9001. Some facilities are also certified ISO 13485:2003.

Inline Check Valves

Standard 1/4-28 Inline Check Valves

- ▶ Add back-flow protection to any 1/4-28 flat-bottom port
- ▶ 15 psi (1 bar) and 3 psi (0.2 bar) cracking pressure versions
- ▶ Excellent chemical resistance
- ▶ Materials of construction: PEEK™; PCTFE; perfluoroelastomer; PTFE (CV-3301 and CV-3302); stainless steel (CV-3301 and CV-3302); or gold-plated stainless steel (CV-3315 and CV-3316)

Connect these Upchurch Scientific® Inline Check Valves to any 1/4-28 flat-bottom port. Then thread your 1/4-28 flat-bottom fitting into the check valve to connect the tubing. Once installed, the spring-actuated sealing system eliminates back flow, helping to prevent upstream contamination or damage. In addition, the unique design of this product eliminates the additional tubing cuts and connections required to install conventional inline check valves.

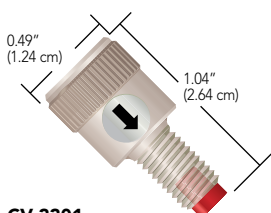

CV-3301
Standard, Inlet
1/4-28 FB Male to 1/4-28 FB Female
15 psi (1 bar) cracking pressure

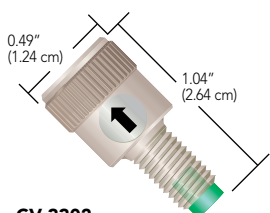

CV-3302
Standard, Outlet
1/4-28 FB Male to 1/4-28 FB Female
15 psi (1 bar) cracking pressure

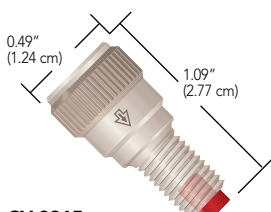

CV-3315
Standard, Inlet
1/4-28 FB Male to 1/4-28 FB Female
3 psi (0.2 bar) cracking pressure

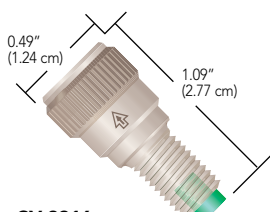

CV-3316
Standard, Outlet
1/4-28 FB Male to 1/4-28 FB Female
3 psi (0.2 bar) cracking pressure

Nonmetallic 10-32 Micro-Volume Inline Check Valve

- ▶ Cracking pressure of 8 psi (0.6 bar)
- ▶ Excellent chemical resistance
- ▶ Materials of construction: PEEK and perfluoroelastomer, suitable for biological applications

With a swept volume of only 7.4 µL, the Upchurch Scientific Inline Micro-Volume Check Valve is perfect for applications where low flow path volume is critical, such as delivery to lab-on-a-chip, single-cell analysis and micro- or nano-LC post-column derivitization. Once installed, this check valve helps prevent back flow and the potential for contamination or damage to sensitive upstream equipment.

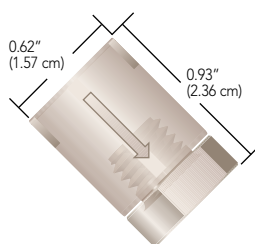

CV-3500
Micro-Volume Inline
10-32 C Female to 10-32 C Female

Note

Check valves are specified by:

- ▶ **Cracking Pressure:** the pressure required for the valve to open in the direction of the arrow
- ▶ **Maximum Pressure:** the maximum pressure the valve can experience in the reverse direction without leaking backwards
- ▶ **Back Pressure Created:** the amount of back pressure generated by the check valve with 50 mL/min room temperature water flowing in the direction of the arrow

Specifications

	Swept Volume	Thru-Hole	Max. Pressure Rating	Back Pressure Created	Cracking Pressure Tolerance
Standard 1/4-28 FB					
CV-3301, CV-3302	20 µL	0.020" (0.50 mm)	2,000 psi (138 bar)	45 psi (3.1 bar)	± 5 psi (0.34 bar)
CV-3315, CV-3316	16 µL	0.020" (0.50 mm)	2,000 psi (138 bar)	10 psi (0.7 bar)	± 1.5 psi (0.10 bar)
Nonmetallic 10-32 Coned Micro-Volume					
CV-3500	7.4 µL	0.010" (0.25 mm)	3,000 psi (207 bar)	25 psi (1.7 bar)	± 5 psi (0.34 bar)

Related Products

- ▶ 1/4-28 Inline Check Valves and Non-Metallic Check Valves with 1/4-28 flat-bottom ports (next page) can be used with any 1/4-28 Flangeless, Super Flangeless™ and VacuTight™ fitting on pages 21 – 28 of the Fittings Chapter.
- ▶ Micro-Volume Inline Check Valves and Non-Metallic Check Valves with 10-32 coned ports (next page) can be used with any 10-32 polymer Fingertight or SealTight™ fitting on pages 11-15. Connect capillary tubing using the optional ferrules listed on page 15 or the NanoTight™ Fittings and Tubing Sleeves on page 17.



Top Seller SEE STARRED PRODUCTS

Part No.	Description	Cracking Pressure
STANDARD 1/4-28 INLINE CHECK VALVES		
CV-3301	Inlet Check Valve, 1/4-28 FB, M to 1/4-28 FB, F*	15 psi (1 bar)
CV-3302	Outlet Check Valve, 1/4-28 FB, M to 1/4-28 FB, F*	15 psi (1 bar)
CV-3315	Inlet Check Valve, 1/4-28 FB, M to 1/4-28 FB, F*	3 psi (0.2 bar)
CV-3316	Outlet Check Valve, 1/4-28 FB, M to 1/4-28 FB, F*	3 psi (0.2 bar)
NONMETALLIC 10-32 MICRO-VOLUME INLINE CHECK VALVE		
CV-3500	Inlet/Outlet Check Valve, 10-32 C, F to 10-32 C, F*	8 psi (0.6 bar)

* M = Male (external) threads; F = Female (internal) threads; C = Coned; FB = Flat-Bottom

Nonmetallic 1/4-28 and 10-32 Inline Check Valves

- ▶ Low cracking pressure of 1 psi (0.07 bar)
- ▶ Multiple configurations for different applications
- ▶ Excellent chemical resistance
- ▶ Materials of construction: PEEK™ and perfluoroelastomer

Upchurch Scientific® Nonmetallic Inline Check Valves provide excellent backflow protection for sensitive equipment along with outstanding chemical resistance guaranteed by the PEEK polymer and perfluoroelastomer construction. Metal-free composition makes these check valves perfect for use with corrosive fluids or biological samples.

These check valves function well up to moderately-high pressure applications. Low internal volume also allows them to be used in areas where flow path volume is important; however, higher flow rates can pass through with minimal pressure drop.

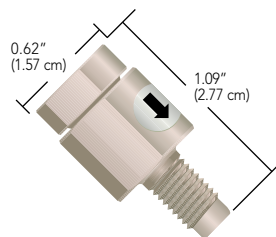

CV-3320, CV-3322, CV-3324
Nonmetallic, Inlet
1/4-28 FB Male to 1/4-28 FB Female

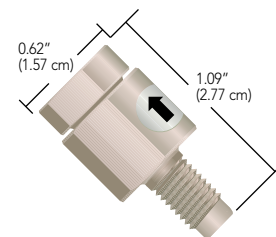

CV-3321, CV-3323, CV-3325
Nonmetallic, Outlet
1/4-28 FB Male to 1/4-28 FB Female

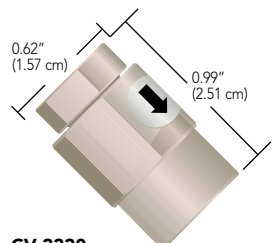

CV-3330
Nonmetallic, Inline
1/4-28 FB Female to 1/4-28 FB Female

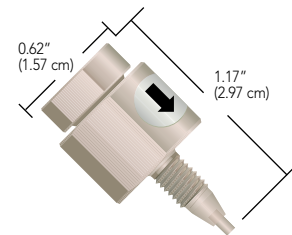

CV-3335
Nonmetallic, Inlet
1/4-28 FB Female to 10-32 C Male

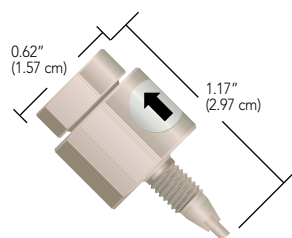

CV-3336
Nonmetallic, Outlet
1/4-28 FB Female to 10-32 C Male

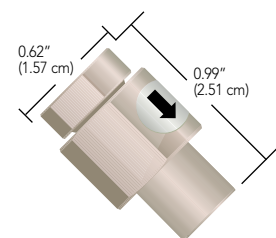

CV-3340
Nonmetallic, Inline
10-32 C Female to 10-32 C Female

Application Note

- ▶ The CV-3320 or CV-3321 style can be connected to any 1/4-28 flat-bottom port for trouble-free back flow protection.
- ▶ When using a pump after the analytical column, consider placing a CV-3330 Check Valve after the column to prevent fluid from the post-column pump from flowing backwards through the column. This product also serves as an excellent nonmetallic alternative to our CV-3010 (page 151) in sparging applications where the mobile phase may be corrosive to the stainless steel or ethylene propylene components inside the CV-3010 assembly.
- ▶ The CV-3335 Inlet and CV-3336 Outlet Check Valves allow tubing larger than 1/16" OD (up to 1/8") to be connected into a 10-32 coned internal port. Use both of these check valves when attaching a larger-volume sample loop to an analytical-scale injection valve. This setup limits the flow of the sample into the loop to one direction, minimizing back flow and sample carry-over.
- ▶ The CV-3340 is useful in virtually any high pressure fluid pathway using 1/16" or smaller OD tubing, where limiting the direction of flow is desirable.

Specifications

	Swept Volume	Max. Pressure Rating	Back Pressure Created	Cracking Pressure Tolerance
CV-3320, CV-3321	37 µL	2,000 psi (138 bar)	30 psi (2.1 bar)	± 0.5 psi (0.03 bar)
CV-3330	34 µL	2,000 psi (138 bar)	30 psi (2.1 bar)	± 0.5 psi (0.03 bar)
CV-3335, CV-3336	49 µL	2,000 psi (138 bar)	30 psi (2.1 bar)	± 0.5 psi (0.03 bar)
CV-3340	34 µL	2,000 psi (138 bar)	30 psi (2.1 bar)	± 0.5 psi (0.03 bar)
CV-3322, CV-3323	49 µL	2,000 psi (138 bar)	30 psi (2.1 bar)	± 0.5 psi (0.03 bar)
CV-3324, CV-3325	182 µL	2,000 psi (138 bar)	30 psi (2.1 bar)	± 0.5 psi (0.03 bar)

Please Note: Upon initial use—or following a period of extended inactivity—the cracking pressure for these check valves may be somewhat higher than the stated cracking pressure.

Part No.	Description	Cracking Pressure	Thru-Hole
NONMETALLIC 1/4-28 AND 10-32 INLINE CHECK VALVES			
★ CV-3320	Inlet Check Valve, 1/4-28 FB, M to 1/4-28 FB, F	1 psi (0.07 bar)	0.020" (0.50 mm)
★ CV-3321	Outlet Check Valve, 1/4-28 FB, M to 1/4-28 FB, F	1 psi (0.07 bar)	0.020" (0.50 mm)
CV-3322	Inlet Check Valve, 1/4-28 FB, M to 1/4-28 FB, F	1 psi (0.07 bar)	0.040" (1.0 mm)
CV-3323	Outlet Check Valve, 1/4-28 FB, M to 1/4-28 FB, F	1 psi (0.07 bar)	0.040" (1.0 mm)
CV-3324	Inlet Check Valve, 1/4-28 FB, M to 1/4-28 FB, F	1 psi (0.07 bar)	0.060" (1.60 mm)
CV-3325	Outlet Check Valve, 1/4-28 FB, M to 1/4-28 FB, F	1 psi (0.07 bar)	0.060" (1.60 mm)
★ CV-3330	Inlet/Outlet Check Valve, 1/4-28 FB, F to 1/4-28 FB, F	1 psi (0.07 bar)	0.020" (0.50 mm)
CV-3335	Inlet Check Valve, 1/4-28 FB, F to 10-32 C, M	1 psi (0.07 bar)	0.020" (0.50 mm)
CV-3336	Outlet Check Valve, 1/4-28 FB, F to 10-32 C, M	1 psi (0.07 bar)	0.020" (0.50 mm)
★ CV-3340	Inlet/Outlet Check Valve, 10-32 C, F to 10-32 C, F	1 psi (0.07 bar)	0.020" (0.50 mm)

* M = Male (external) threads; F = Female (internal) threads; C = Coned; FB = Flat-Bottom



Top Seller SEE STARRED PRODUCTS

Inline Check Valves

Quick-Stop Luer Inline Check Valve

- ▶ Check valve protection with luer convenience
- ▶ Remains open when engaged
- ▶ Materials of construction: PEEK™, perfluoroelastomer, and gold-plated stainless steel spring

The Quick-Stop Luer Check Valve is designed to provide inline luer connect/disconnect convenience without the mess and hazard of spills. Just connect the valve assembly to your inline tubing using standard 1/4-28 flat-bottom fittings (see pages 22–29). The check valve is automatically opened once the luer connection is engaged, allowing flow in either direction. Disconnecting the luer union causes the check valve to close. Please see the “Application Note” box on this page for specific ideas regarding use of this valve.



P-696 Quick-Stop Luer Check Valve Assembly

Inline Cartridge Check Valves

- ▶ Low cracking pressures
- ▶ Less than 150 µL internal volume
- ▶ Materials of construction: PEEK; perfluoroelastomer (CV-3001); gold-plated stainless steel spring (CV-3001); ethylene propylene (CV-3011); and stainless steel spring (CV-3011)

Upchurch Scientific® cartridge-style Inline Check Valves are designed to limit flow to one direction. These assemblies withstand system pressures of 1,000 psi (69 bar). The cracking pressures for the Inline Check Valve Cartridges are 1.5 psi (0.1 bar) for the CV-3001 and 3 psi (0.2 bar) for the CV-3011. Tolerance on the cracking pressure for CV-3001 is ± 0.5 psi (0.03 bar) and ± 1.5 psi (0.1 bar) on CV-3011.

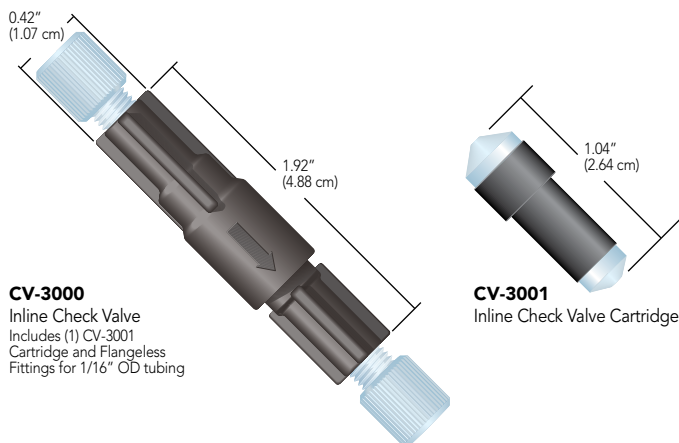

CV-3000
Inline Check Valve
Includes (1) CV-3001
Cartridge and Flangeless
Fittings for 1/16" OD tubing

CV-3001
Inline Check Valve Cartridge

Application Note

Inlet Solvent Reservoir:

Quickly change your solvent on the low pressure end of an HPLC system, while preventing potentially hazardous spills! Just install a Quick-Stop Luer Check Valve Assembly between your solvent reservoir and the pump, with the valve towards the bottle. The valve will prevent solvent leakage from the line coming from the reservoir, while the check valves in your pump prevent spills from the line leading to the pump. With both lines still full of solvent, this system also helps reduce the need to reprime your pump.

FIA Sample Injection:

The Quick-Stop Luer Check Valve provides a practical means to introduce a sample into FIA and other low pressure systems, when used in conjunction with a P-612 Pressure Relief Valve Tee (page 154). Simply connect the Tee into the appropriate flow path line with the included fittings and thread the P-697 Quick-Stop Luer Valve onto the 1/4-28 male end of the Tee. Sample can then be introduced conveniently by using a standard luer-tipped syringe. The check valve is automatically opened when the syringe is attached and closed when the syringe is removed.

Post Column Derivatization:

For post-column derivatization, place a CV-3000 Inline Check Valve on the effluent side of your column to prevent derivatizing agents from flowing backwards and poisoning the column. Placement on the post-column reagent line will also prevent mobile phase from contaminating the reagent if the auxiliary pump fails.

Helium Sparging Tank Protection:

Try the CV-3010 Assembly, designed specifically for degassing (sparging) lines to prevent solvent backup if the sparging gas runs out. This check valve will help prevent potential solvent cross-contamination and damage to the gas regulating valve.



Top Seller SEE STARRED PRODUCTS

Part No.	Description	Includes	Swept Volume	Price
QUICK-STOP LUER CHECK VALVE				
P-696	Quick-Stop Luer Check Valve Assembly	(1) P-697, (1) P-655	127 µL	\$ 75.80
★ P-697	Quick-Stop Luer Check Valve		107 µL	61.73
P-698	Bulkhead Quick-Stop Luer Valve Assembly	(1) P-699, (1) P-655, (1) nut/lock washer set	127 µL	82.09
P-699	Bulkhead Quick-Stop Luer Valve	(1) nut/lock washer set	107 µL	68.10
INLINE CARTRIDGE CHECK VALVES				
★ CV-3000	Inline Check Valve Assembly for 1/16" OD tubing	(1) CV-3001, (2) XP-215	96 µL	\$ 83.11
CV-3001	Inline Check Valve Cartridge for CV-3000		91 µL	55.39
CV-3010	Inline Check Valve Assembly for 1/8" OD tubing	(1) CV-3011, (2) XP-315	100 µL	83.11
CV-3011	Inline Check Valve Cartridge for CV-3010		92 µL	55.39

Back Pressure Regulators (BPRs)

- ▶ Proven outgassing protection
- ▶ Flow-independent pump preload for greater pump efficiency
- ▶ 5 to 1,000 psi cartridges and assemblies available

Back Pressure Regulators are designed to enhance system performance through outgassing prevention and improved pump check valve efficiency.

Upchurch Scientific® back pressure regulators include:

- ▶ 5 and 20 psi assemblies (replacement cartridges not available)
- ▶ 40, 75, 100, 250, 500, 750 and 1,000 psi cartridges and assemblies
- ▶ PEEK™ and stainless steel BPR holders
- ▶ High pressure adjustable BPR for pressures between 2,000 and 5,000 psi
- ▶ Ultra low volume BPRs set to 100 and 500 psi (page 154)

Please Note: For flow control options try the Micro-Metering Valves found on page 147.



Biocompatible Back Pressure Regulator Holder, shown with available Cartridges

Application Note

Small gas bubbles often form as solvent moves from the high pressure of an HPLC column to the low pressure environment leading to the detector. This outgassing can cause erratic baseline readings and loss of sensitivity. Placing an Upchurch Scientific BPR (usually a 40 – 100 psi) after the detector provides an excellent, low-cost method for reducing this problem by maintaining enough back pressure on the mobile phase to keep gases dissolved in solution.

A back pressure regulator can also be used as a pump preload for low and fluctuating pressure applications. Many of today's pumps require a steady back pressure to function properly. Install an Upchurch Scientific BPR (usually 500–1,000 psi) between the pump and the injector to enhance pump performance.

Caution: Do not exceed the maximum operating pressure of your system—please refer to the operating manuals for your system components before choosing the appropriate BPR.

BPR Assemblies

Choose from our line of Biocompatible and Stainless Steel BPR Assemblies, each complete with a replaceable, factory preset cartridge (except the 5 and 20 psi versions).

Upchurch Scientific BPR Assemblies create incremental back pressures ranging from 5 to 1,000 psi (0.3 to 69 bar). The Biocompatible BPR Assemblies feature a PEEK holder; polymer-based fittings; biocompatible BPR cartridges and wrenches for tightening. Stainless Steel BPR Assemblies feature the same biocompatible BPR cartridges with a 316 stainless steel holder and polymer fittings.

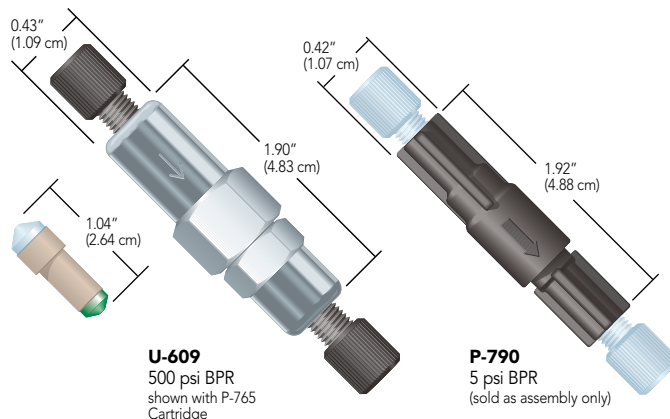

U-609
500 psi BPR
shown with P-765
Cartridge

P-790
5 psi BPR
(sold as assembly only)

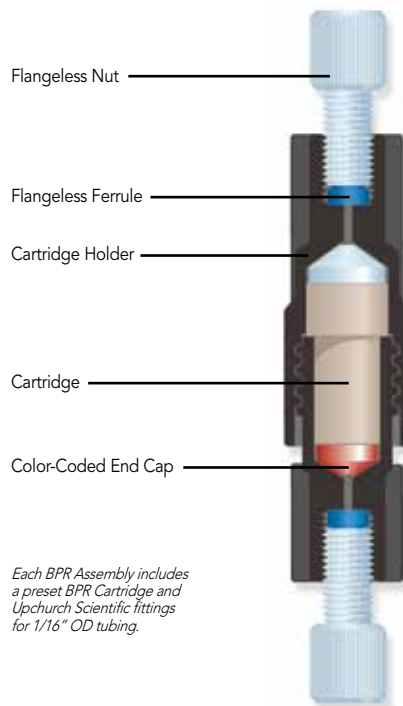

Each BPR Assembly includes a preset BPR Cartridge and Upchurch Scientific fittings for 1/16" OD tubing.

Back Pressure Regulators

Replacement Back Pressure Regulator (BPR) Cartridges

- Materials of construction: PEEK™, ETFE, perfluoroelastomer, and gold-plated stainless steel

These replacement cartridges will operate in any of the standard BPR holders shown on this page. These cartridges create back pressures from 40 to 1,000 psi (2.8 to 69 bar)—all independent of flow except as noted below.

The recommended operating flow rate range for our BPR Cartridges is 0.1 mL – 10 mL/min. Within this range, the amount of back pressure created by the BPR Cartridges and Assemblies will not vary more than ±10%. Lower or higher flow rates may result in larger pressure fluctuations.

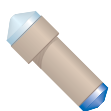

P-761
40 psi BPR Cartridge



P-796
1,000 psi BPR Cartridge

BPR Holders

Upchurch Scientific® P-465 PEEK and U-469 Stainless Steel BPR Holders work with any of our replacement BPR Cartridges. Each holder comes with fittings for 1/16" OD tubing (see below). The U-469 Holder is surface-treated to prevent galling, a potential problem with large, threaded metal parts.

Please Note: These Back Pressure Regulator Holders are designed to allow each cartridge to operate at its stated pressure setting when tightened to 20 in-lbs. of torque. To approximate this level of torque, first finger tighten the Holder, then tighten an additional 1/8–1/4 turn with the supplied wrenches.

Pressure Rating **3,000 psi (207 bar)***

LT-115
LiteTouch® Nut
(page 16)

P-250
Super
Flangeless™
Ferrule
(page 21)

P-465
PEEK BPR
Holder
(cartridge sold
separately)



Pressure Rating **4,000 psi (276 bar)****

F-300
Two-Piece
Fingertight
Fitting
(page 15)

U-469
Stainless
Steel
BPR Holder
(cartridge sold
separately)



* Using PEEK tubing and supplied fittings

** Using stainless steel tubing and supplied fittings

High Pressure Adjustable BPR

- Materials of construction: PEEK, perfluoroelastomer, and PTFE

The biocompatible P-880 High Pressure Adjustable BPR offers the flexibility to adjust your system back pressure between 2,000 and 5,000 psi (138 and 345 bar), independent of the flow. Only 10% fluctuation in pressure generally occurs with flow rates of 0.1 – 10 mL/min. Lower or higher flow rates will lead to greater fluctuations in pressure. To achieve the desired back pressure setting, simply turn the thumbscrew while monitoring your system pressure. Because this product creates such high back pressure, please check system component specifications prior to using to avoid damaging any sensitive components.

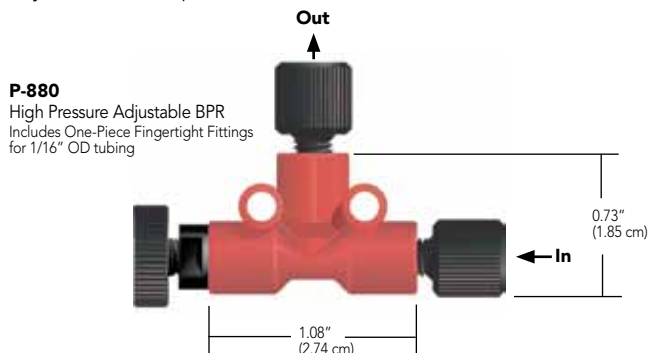

P-880
High Pressure Adjustable BPR
Includes One-Piece Fingertight Fittings
for 1/16" OD tubing



Top Seller SEE STARRED PRODUCTS

Part No.	Pressure Setting	Holder Material	Includes	Swept Volume
BPR ASSEMBLIES				
P-790	5 psi (0.3 bar)	PEEK	(2) XP-215	134 µL
★ P-791	20 psi (1.4 bar)	PEEK	(2) XP-215	134 µL
★ P-785	40 psi (2.8 bar)	PEEK	(1) P-761, (2) XP-215	131 µL
★ P-786	75 psi (5.2 bar)	PEEK	(1) P-762, (2) XP-215	131 µL
★ P-787	100 psi (7 bar)	PEEK	(1) P-763, (2) XP-215	131 µL
P-788	250 psi (17 bar)	PEEK	(1) P-764, (2) XP-235	102 µL
P-789	500 psi (34 bar)	PEEK	(1) P-765, (2) P-250, (2) LT-115	96 µL
P-455	1,000 psi (69 bar)	PEEK	(1) P-796, (2) P-250, (2) LT-115	89 µL
U-605	40 psi (2.8 bar)	SST	(1) P-761, (2) XP-201	129 µL
U-606	75 psi (5.2 bar)	SST	(1) P-762, (2) XP-201	129 µL
★ U-607	100 psi (7 bar)	SST	(1) P-763, (2) XP-201	129 µL
U-608	250 psi (17 bar)	SST	(1) P-764, (2) XP-201	99 µL
U-609	500 psi (34 bar)	SST	(1) P-765, (2) XP-201	93 µL
U-610	750 psi (52 bar)	SST	(1) P-795, (2) P-250, (2) LT-115	91 µL
REPLACEMENT CARTRIDGES				
COLOR CODING				
Part No.	Pressure Setting	Body	End-Cap	Swept Volume
P-761	40 psi (2.8 bar)	Tan	Blue	125 µL
P-762	75 psi (5.2 bar)	Tan	Yellow	125 µL
★ P-763	100 psi (7 bar)	Tan	Red	125 µL
P-764	250 psi (17 bar)	Tan	White	95 µL
P-765	500 psi (34 bar)	Tan	Green	89 µL
P-795	750 psi (52 bar)	Black	Blue	87 µL
P-796	1,000 psi (69 bar)	Black	Green	83 µL
BPR HOLDERS				
Part No.	Holder Style	Holder Material	Includes	Swept Volume
P-465	Biocompatible BPR	PEEK	(2) P-250, (2) LT-115	7 µL
U-469	High Pressure BPR	SST	(2) F-300	4 µL
HIGH PRESSURE ADJUSTABLE BPR ASSEMBLY				
★ P-880	2,000 – 5,000 psi (138-345 bar)		(2) F-120BLK	9 µL

Ultra-Low Volume Back Pressure Regulators (BPR)

- ▶ Wetted flow path materials: PEEK™, perfluoroelastomer, and ETFE
- ▶ Available pressure settings of 100 or 500 psi (7 or 34 bar)
- ▶ Low swept volume of only 6 µL

Ultra-Low Volume Back Pressure Regulators (BPRs) were developed to minimize swept volume, which is especially important for multi-detector applications. With a maximum swept volume of only 6 µL*, it is nearly impossible to detect these BPRs as part of your fluid pathway (please see "Difficult to Detect" below for more details). To minimize the swept volume added to your flow path, we recommend trimming the length of the attached tubing. And because the flow path is completely polymeric, you are assured of biocompatibility.



Please Note: Our Ultra-Low Volume Back Pressure Regulators cannot be used as check valves due to their unique internal design. Try our Micro-Volume Inline Check Valve on page 149.

* The maximum internal swept volume listed above is for the back pressure regulator only and does not include the volume of the attached tubing lines.

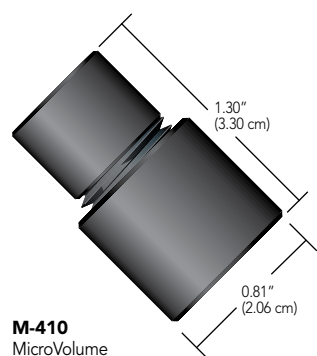

M-410
MicroVolume
BPR Assembly
Attached tubing not shown

Pressure Relief Valves

- ▶ Prevent system over-pressurization

Upchurch Scientific® Pressure Relief Valves are ideal for preventing system over-pressurization. These products protect system components by diverting fluid flow automatically when inline pressure exceeds the set limit. Choose between preset 100 psi (7 bar) and 5 psi (0.3 bar) assemblies, both shipped with Flangeless Fittings. The 100 psi version is a good, general purpose valve, while the 5 psi version is perfect for protecting syringe and peristaltic pump systems (see pages 93–108). The void volume of both relief valves is low due to the small 0.020" (.50 mm) thru-holes in the valve tee body.

If you wish to have the Pressure Relief Valve open at a different pressure than 5 or 100 psi, simply combine one of the other replacement Back Pressure Regulator Assemblies listed on page 152 with the P-612 Pressure Relief Valve Tee. Choose the P-612S for larger bore tubing and higher flow applications.

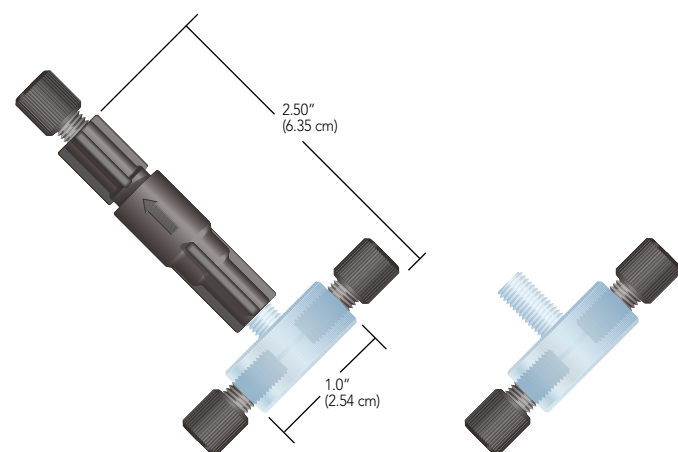

U-455
Pressure Relief Valve
Includes Flangeless Fittings
for 1/16" OD tubing
(Drawing is not actual size)

P-612
Pressure Relief Valve Tee
Includes Flangeless Fittings
for 1/16" OD tubing
(Drawing is not actual size)

Specifications

	Back Pressure Setting psi (bar)	Flow Rate Recommendations	Recommended Pressure Range psi (bar)	1/16" OD Tubing
M-410	100 ² (7) ²	Optimal: 100 µL–1 mL/min Max.: 4 mL/min	40–150 (3–10)	PEEK, 0.010" ID
M-412	500 ² (34) ²	Optimal: 100 µL–1 mL/min Max.: 4 mL/min	250–525 (17–36)	PEEK, 0.010" ID
M-420	100 ³ (7) ³	Optimal: 3–8 mL/min Max.: 10 mL/min	40–150 (3–10)	PEEK, 0.020" ID

¹ All data generated using water at room temperature

² Set at a flow rate of 0.5 mL/min

³ Set at a flow rate of 5 mL/min



Top Seller SEE STARRED PRODUCTS

Part No.	Description	Pressure Setting	Tubing OD	Includes	Swept Volume
ULTRA-LOW VOLUME BPRs					
M-410	Low Flow	100 psi (7 bar)	1/16"	XP-230	6 µL
★ M-412	Low Flow	500 psi (34 bar)	1/16"	XP-230	6 µL
M-420	High Flow	100 psi (7 bar)	1/16"	XP-230	6 µL
PRESSURE RELIEF VALVES					
U-455	Pressure Relief Assembly	5 psi (0.3 bar)	1/16"	XP-201	148 µL
★ U-456	Pressure Relief Assembly	100 psi (7 bar)	1/16"	XP-201, wrenches	139 µL
★ P-612	Pressure Relief Tee		1/16"	XP-201	14 µL
P-612S	Pressure Relief Tee		3/16"	XP-201	348 µL

Prime/Purge Valves

Prime/Purge Valve for Waters® Pumps

- ▶ Automatic valve operation with a simple twist of a luer lock syringe
- ▶ No tubing to cut or ferrules to swage
- ▶ No wear on the internal seal
- ▶ Materials of construction: ruby, sapphire, PEEK™, PTFE, and stainless steel

The Upchurch Scientific® Prime/Purge Valve for Waters pumps automatically opens when a luer syringe is attached and closes when the syringe is removed. No valve rotation is required after the initial installation, so wear on the internal seal is eliminated.

In addition, our Waters-compatible Prime/Purge Valve is simpler to operate and more economically priced than alternative valves available for Waters systems.

A Waters-compatible internal PTFE seal is included with the valve. This seal can also be purchased separately. It can be used both with the Upchurch Scientific valve and the original valve supplied with the pump.



Universal Prime/Purge Valve

- ▶ For any style HPLC system
- ▶ Automatic luer syringe operation
- ▶ Featuring handy mounting holes
- ▶ Materials of construction: ruby, sapphire, PEEK, PTFE, and stainless steel

The Upchurch Scientific Universal Prime/Purge Valve is easy to operate. Simply install a valve along the flow path with the included fittings and attach a luer-tipped syringe. Then, withdraw the plunger and watch as solvent and residual bubbles are removed from the solvent line. The valve automatically closes when the syringe is removed.



The valve is designed to be used with 1/8" OD tubing. Optional mounting is made easy by the handy holes in the body of each unit.

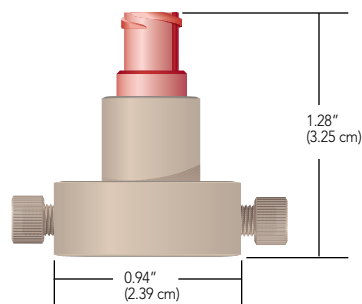

V-321
Universal Prime/Purge Valve
Mounting holes are 0.75" (1.91 cm) apart

Attaching/Removing the Syringe Automatically Opens and Closes the Valve

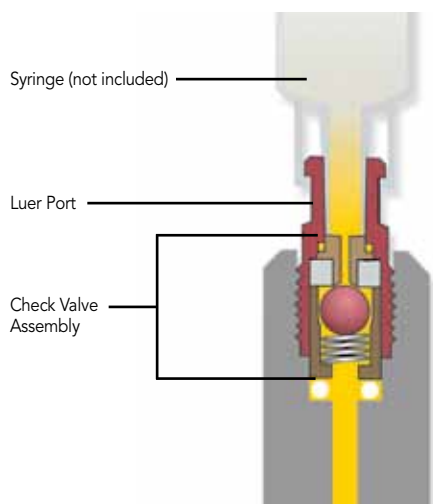

Application Note

Air in the Inlet Solvent Line

Install the Low Pressure Universal Prime/Purge Valve along the inlet solvent path near the pump to remove bubbles from the inlet solvent line. The valve can also be used to rapidly "wet" your solvent inlet filter. When a new filter is installed, it often contains a substantial amount of air within its pores. At standard flow rates, it may require several minutes before the inlet fluid pathway is completely free of gas. Using this valve you are able to rapidly draw solvent through the inlet filter, dislodging the gas and minimizing downtime.

Part No.	Description	Includes
PRIME/PURGE VALVES		
B-310	10cc Disposable Luer-Tipped Syringe	
V-320	Prime/Purge Valve for Waters Pumps	(1) V-320-06
V-320-06	Replacement PTFE Seal (for V-320)	
V-321	Universal Prime/Purge Valve	(2) P-300N, (2) P-335