

# Valves



Installing a sample loop on a Rheodyne® manual sample injection valve in Rohnert Park, CA

## Dear Customer

We are pleased to present our 2011/2012 catalog, which includes Innovadyne™, Ismatec®, Isolation Technologies™, Rheodyne®, Systemc®, and Upchurch Scientific® products. In this catalog, you will find all the critical fluidic products and high-quality components you've come to expect from IDEX Health & Science.

This catalog has a new 'look and feel', with a new organization to all of our products. Now, you will be able to find all of our fittings in one chapter, with separate chapters for products like tubing, valves, pumps, etc. And, as always, we have many new products – including some very innovative UHPLC fittings and accessories – scattered throughout the catalog that we hope will prove useful to you.

We appreciate your business and continued loyalty to our family of products and services and thank you for trusting IDEX Health & Science with your liquid handling needs. Your feedback is valuable, so please let us know if there are ways we can be of greater service.



**Joe Stupfel**

VP Marketing & Research, Development & Engineering  
IDEX Health & Science LLC

## IDEX Health & Science Contact Information

### NORTH / SOUTH AMERICA

#### **IDEX Health & Science LLC**

619 Oak Street  
Oak Harbor, WA 98277 USA  
Tel: +1 800 426 0191  
Fax: +1 800 359 3460  
Fax: +1 360 679 3830  
E-mail: CustomerService.hs@idexcorp.com

### EUROPE

#### **IDEX Health & Science GmbH**

Futtererstrasse 16  
97877 Wertheim  
Germany  
Tel: +49 (0) 1801 808 800  
Fax: +49 (0) 9377 1388  
E-mail: CustomerService.hseurope@idexcorp.com

### ASIA

#### **IDEX Trading (Shanghai) Co. Ltd**

Room 1701A  
CBD International Plaza  
No. 16 Yong An Dong Li  
Beijing, China 100022  
Tel: +86 10 6566 9090  
Fax: +86 10 6567 5152  
E-mail: CustomerService.hsasia@idexcorp.com

#### **IDEX Asia Pacific Pte Ltd**

63 Hillview Avenue #07-08  
Lam Soon Industrial Building  
Singapore 669569  
Tel: +65 6314 6145  
Fax: +65 6764 4020  
E-mail: CustomerService.hsasia@idexcorp.com

#### **IDEX India Pvt Ltd**

205, Matharu Arcade  
Plot No. 32 Subhash Road  
Vile Parle (East)  
Mumbai – 400 057 India  
Tel: +91 22 66 78 00 50  
Fax: +91 22 66 78 00 55  
E-mail: CustomerService.hsasia@idexcorp.com

#### **IDEX Health & Science**

6F Sanseido Bldg.  
2-4 Kojimachi, Chiyoda-ku,  
Tokyo 102-0083, Japan  
Tel: +81 3 3263 5390  
Fax: +81 3 3511 5890  
E-mail: CustomerService.hsasia@idexcorp.com

# Ordering Information

## How to Order

### Direct from IDEX Health & Science

#### For North America orders:

**Tel:** +1 800 426 0191 ▶ +1 360 679 2528

**Fax:** +1 800 359 3460 ▶ +1 360 679 3830

**E-mail:** [CustomerService.hs@idexcorp.com](mailto:CustomerService.hs@idexcorp.com)

#### For Europe orders:

**Tel:** +49 (0) 1801 808 800

**Fax:** +49 (0) 9377 1388

**E-mail:** [CustomerService.hseurope@idexcorp.com](mailto:CustomerService.hseurope@idexcorp.com)

#### For Asia orders:

**E-mail:** [CustomerService.hsasia@idexcorp.com](mailto:CustomerService.hsasia@idexcorp.com)

##### NORTH ASIA

**Tel:** +86 10 6566 9090

**Fax:** +86 10 6567 5152

##### SOUTH AND SOUTHEAST ASIA

**Tel:** +91 22 66 78 00 50

**Fax:** +91 22 66 78 00 55

##### JAPAN

**Tel:** +81 3 3263 5390

**Fax:** +81 3 3511 5890

#### For Online orders:

**Web:** [www.idex-hs.com](http://www.idex-hs.com)

Please include the following information with your order: Purchase Order Number, Contact Name, Shipping and Billing Address, Telephone Number, Product Number(s) and Quantity(ies). If you are a Purchasing Agent, please include the name of the person for whom the products are ordered.

For your information, our Federal Taxpayer Identification number is 01-0736657.

### Order Processing/Shipping

Orders process within one business day and ship within two business days. Requests for earlier shipments can be made — please contact IDEX Health & Science for more details.

All shipments are FCA unless otherwise noted. Shipping charges will be prepaid and added to the invoice. Or, if requested, we will charge your carrier account number.

### Terms



Terms of payment are net 30 days. Mastercard®, Visa® and American Express® are accepted.

There is no minimum order. Customers are responsible for C.O.D. charges if they elect this payment method. Terms and prices are subject to change without notice. Visit [www.idex-hs.com](http://www.idex-hs.com) for complete Terms & Conditions.

### Return of Materials

Returns must be authorized in advance. Please contact us within 30 days of purchase for your Returns Material Authorization (RMA) Number. A restocking fee may apply.

### Direct from our Global Distribution Network

The IDEX Health & Science brands represented in this catalog (Innovadyne™, Ismatec®, Isolation Technologies™, Rheodyne®, Systec®, and Upchurch Scientific®) have established relationships with a large, global network of Distributors, many of whom can offer the product support and assistance that we cannot, including:

- ▶ Carrying local inventory of commonly-ordered items
- ▶ Understanding YOUR working environment and requirements
- ▶ Providing technical application assistance
- ▶ Answering questions regarding new and existing products
- ▶ Complete availability during your time zone business hours
- ▶ Personal visits as required
- ▶ Access to complementary product lines to provide a "one-stop shopping" experience

We have come to rely on our authorized Distributors to provide value-added service to end-users of our products. So, while we are happy to take your order directly, we encourage you to contact your local Distributor — we feel confident it will be a positive experience!

### How to Find A Local Distributor

For a complete distributor listing please visit [www.idex-hs.com/distributors](http://www.idex-hs.com/distributors) or email:

**US:** [CustomerService.hs@idexcorp.com](mailto:CustomerService.hs@idexcorp.com)

**Europe:** [CustomerService.hseurope@idexcorp.com](mailto:CustomerService.hseurope@idexcorp.com)

**Asia:** [CustomerService.hsasia@idexcorp.com](mailto:CustomerService.hsasia@idexcorp.com)

Our customer service team will help you contact a distributor in your area.

### Return of Materials

Product purchased through a Distributor must be returned directly to that Distributor. Please contact them for Return Material Authorization procedures.

Visit Us At  [WWW.IDEX-HS.COM](http://WWW.IDEX-HS.COM)

*The products in this catalog are intended for use with analytical, biotechnology and diagnostic equipment and accessories. THE MANUFACTURERS OF THE PRODUCTS IN THIS CATALOG SHALL HAVE NO LIABILITY WHATSOEVER DUE TO ANY MISUSE OF THEIR PRODUCTS. Of course, the safe use of our products depends on our customers, since it is you who select and control the protective gear and safety procedures used, as well as the pressures, temperatures, solvents, samples, ventilation, and other variables. Product and material performance ratings are provided as guides only. Individual field tests should be performed by customers to determine safe operating parameters given your particular procedures and use.*

IDEX Health & Science facilities are certified ISO 9001. Some facilities are also certified ISO 13485:2003.

## High Pressure Valves

Rheodyne® valves fit virtually any flow control application. There are valves for preparative, analytical, nano, and microscale analysis in a variety of flow configurations. Pressure ratings of the valves in this chapter range from 125 psi (9 bar) to 15,000 psi (1,034 bar).

MX Series II™ Modules are actuated electronically and can be easily adapted to existing instrumentation using contact closure, BCD, I<sup>2</sup>C, USB, or used as stand alone devices. Industry standard sample injectors and switching valves are designed for manual actuation. Locate the valve module and flow configuration of choice using the table below.

### Valve Configurations

Valve Module	Flow Configuration	Connecting Tubing Size	Page
<b>MXT Modules: Very High Pressure (&lt;15,000 psi)</b>	<ul style="list-style-type: none"> <li>• 2-position, 10-port Switching</li> <li>• 6-position, 7-port Selection</li> <li>• 2-position, 6-port Switching</li> </ul>	1/16" OD	127
<b>MXP Modules: High Pressure (&lt;6,000 psi)</b>	<ul style="list-style-type: none"> <li>• 2-position, 6-port Switching (analytical and nano scale)</li> <li>• 2-position, 6-port Vertical Port Switching</li> <li>• 2-position, 10-port Selection (analytical and nano scale)</li> <li>• 6-position, 7-port Selection</li> </ul>	1/32" or 1/16" OD	127
<b>MXS Modules: Low Pressure (&lt;125 psi)</b>	<ul style="list-style-type: none"> <li>• 2-position, 6-port Switching</li> <li>• 2-position, 6-port Double 3-Way Switching</li> <li>• 6-position, 7-port Selection</li> <li>• 10-position, 11-port Selection</li> </ul>	1/16" or 1/8" OD	141
<b>Manual Sample Injectors</b>	<ul style="list-style-type: none"> <li>• Dual Mode Analytical, Micro and Preparative Scale Injector</li> <li>• Single Mode Analytical and Micro Scale Injectors</li> </ul>	0.020", 1/16" or 1/8" OD	131 – 132
<b>Manual Switching Valves</b>	<ul style="list-style-type: none"> <li>• 2-position, 6-port Switching</li> <li>• 2-position, 6-port 3-Way and 4-Way Switching</li> <li>• 6-position, 7-port Selection</li> </ul>	1/16" or 1/8" OD	133

Genuine Rheodyne valve accessories are also featured in this chapter. Please see the pages indicated below for more information on these valve consumables:

- ▶ Vespel®, ETFE, and PEEK™ rotor seals; stainless steel, PEEK, and propriety material stators (page 134)
- ▶ Rheodyne RheBuild® Kits (page 135)
- ▶ Stainless steel and PEEK sample loops (page 136 and 137)
- ▶ Needle port accessories, mounting brackets, and the IDEX Wrench (page 139 and 140)



## High Pressure Valves

## MXT Valves for Fast Chromatography

- ▶ Valves for proprietary ultra-high performance applications
- ▶ Can withstand up to 15,000 psi (1,034 bar)
- ▶ Made from combination UltraLife™ material
- ▶ Available in a two-position and a six-position version
- ▶ Designed for use Rapid Replacement Pod™ for quick and easy maintenance



## MXP High Pressure Valves for HPLC

- ▶ Switching, selection, and injection valve models
- ▶ Can withstand up to 6,000 psi (414 bar)
- ▶ Chemically compatible for use with most mobile phase compositions
- ▶ Available with analytical and nano-scale flow paths



## Related Products

- ▶ VHP Fittings on pages 6 – 7
- ▶ Fittings for Coned Ports on pages 10 – 17
- ▶ Fittings for M4 Ports on page 12
- ▶ Tubing Sleeves to connect capillary tubing into 1/16" or 1/32" OD ports on page 20



**Top Seller** SEE STARRED PRODUCTS

Please note: flow paths for the MX Series II™ modules can be viewed on page 128.

## Specifications

<b>Flow Passages</b>	Nano: 0.10 mm (0.004") diameter Analytical: 0.25 mm (0.010") diameter
<b>Power Requirements</b>	100–120 V <sub>AC</sub> , 50–60 Hz
<b>Regulatory Compliance</b>	CE Mark
<b>Remote Control</b>	USB, i°C, BCD, Level Logic
<b>Operating Temperature</b>	0 °– 40 °C, non-condensing
<b>Storage Temperature</b>	0 °– 75 °C
<b>Dimensions ( H x W x D )</b>	117 mm x 76 mm x 128 mm (4.6" x 3.0" x 5.0")

Part No.	Description	Pressure Rating	Connections	Wetted Material	Rapid Replacement Pod
<b>MXT HPLC VALVES</b>					
★ MXT715-000	2-position, 6-port, Switching Valve, MX, TitanHT™, VHP	15,000 psi (1,035 bar)	10-32 ports for 1/16" OD Tubing	UltraLife	PD715-000
MXT715-102	2-position, 10-port, Switching Valve, MX, TitanHT, VHP	15,000 psi (1,035 bar)	10-32 ports for 1/16" OD Tubing	UltraLife	PD715-102
MXT715-105	6-position, 7-port, Selection Valve, MX, TitanHT, SEL	15,000 psi (1,035 bar)	10-32 ports for 1/16" OD Tubing	UltraLife	PD715-105
<b>MXP HPLC VALVES</b>					
MXP7900-000	2-position, 6-port, Switching Valve, MX, TitanHP™	6,000 psi (410 bar)	10-32 ports for 1/16" OD Tubing	DuraLife®*	PD7900
MXP7920-000	2-position, 6-port, Vertical Port Injector, MX, TitanHP, VP	6,000 psi (410 bar)	10-32 ports for 1/16" OD Tubing	DuraLife	PD7920
MXP7960-000	2-position, 10-port, Switching Valve, MX, TitanHP	6,000 psi (410 bar)	10-32 ports for 1/16" OD Tubing	DuraLife	PD7960
MXP7970-000	6-position, 7-port, Selection Valve, MX, TitanHP	6,000 psi (410 bar)	10-32 ports for 1/16" OD Tubing	DuraLife II**	PD7970
MXP7980-000	2-position, 6-port, Nano Switching Valve, MX, TitanHP	6,000 psi (410 bar)	M4 ports for 1/32" OD Tubing	DuraLife II	PD7980
MXP7986-000	2-position, 10-port, Nano Switching Valve	6,000 psi (410 bar)	M4 ports for 1/32" OD Tubing	DuraLife II	PD7986
★ MXP9900-000	2-position, 6-port, Biocompatible Switching Valve, MX, TitanHP, SEL	6,000 psi (410 bar)	10-32 ports for 1/16" OD Tubing	PEEK™	PD9900
MXP9960-000	2-position, 10-port, Biocompatible Switching Valve, MX, TitanHP	6,000 psi (410 bar)	10-32 ports for 1/16" OD Tubing	PEEK	PD9960

\* Duralife is a proprietary material combination of SST and an advanced polymer.

\*\* Duralife II is a proprietary material combination consisting of Titanium and an advanced polymer.

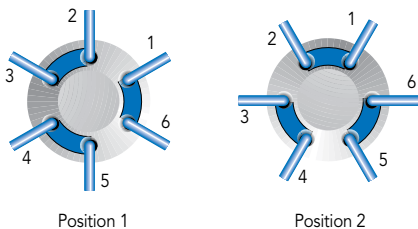

Flow path of MX Series II™ Two-Position, Six-Port Switching Valve

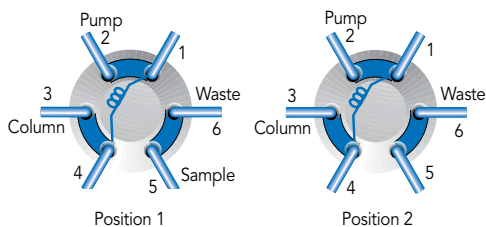

Flow path of MX Series II Two-Position, Six-Port as an Injection Valve

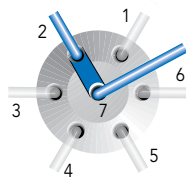

Flow path of MX Series II Six-Position, Seven-Port Selector Valve

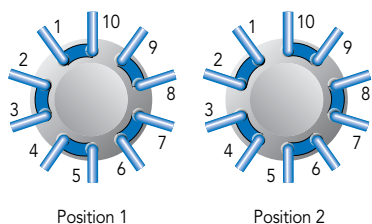

Flow path of MX Series II Two-Position, Ten-Port Switching Valve

Application Note

The high pressure MX Series II can increase sample throughput and laboratory productivity by automating HPLC applications. These applications can be automated with the addition of the high pressure MX Series II valve to an existing HPLC System, saving money and allowing for simple connections with little set-up time.

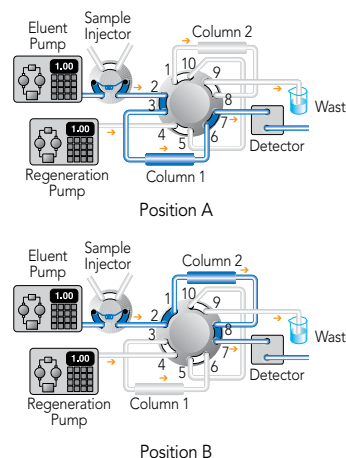

Alternating column regeneration using Rheodyne® Two-Position, Ten-Port MXP Module (P/N MXP7960-000, page 127)

Part No.	Description	Qty.		
<b>REPLACEMENT PODS</b>				
PD715-000	Rapid Replacement Pod™ for MXT715-100	ea.		
PD715-102	Rapid Replacement Pod for MXT715-102	ea.		
PD715-105	Rapid Replacement Pod for MXT715-105	ea.		
PD7900	Rapid Replacement Pod for MXP7900-000	ea.		
PD7920	Rapid Replacement Pod for MXP7920-000	ea.		
PD7960	Rapid Replacement Pod for MXP7960-000	ea.		
PD7970	Rapid Replacement Pod for MXP7970-000	ea.		
PD7980	Rapid Replacement Pod for MXP7980-000	ea.		
PD7986	Rapid Replacement Pod for MXP7986-000	ea.		
PD9900	Rapid Replacement Pod for MXP9900-000	ea.		
PD9960	Rapid Replacement Pod for MXP9960-000	ea.		
<b>REPLACEMENT FITTINGS</b>				
6000-209	Stainless Steel Standard Fittings, with 6000-210 Ferrules, 1/16", 10-32	10-pk		
6000-282	RheFlex One-piece Fittings, 1/16", 10-32, PEEK™, Natural	10-pk		
6000-360	M4 RheFlex Fittings, 1/32", PEEK, Natural	10-pk		
<b>FAST CHROMATOGRAPHY SAMPLE LOOPS</b>				
Part No.	Description	Pressure Rating	Volume	Qty.
7755-300	Stainless Steel Sample Loop	30,000 psi (2,070 bar)	5 µL	ea.
7755-301	Stainless Steel Sample Loop	30,000 psi (2,070 bar)	10 µL	ea.
7755-302	Stainless Steel Sample Loop	30,000 psi (2,070 bar)	20 µL	ea.
7755-303	Stainless Steel Sample Loop	30,000 psi (2,070 bar)	50 µL	ea.
7755-304	Stainless Steel Sample Loop	30,000 psi (2,070 bar)	100 µL	ea.
<b>REPLACEMENT FITTINGS</b>				
VHP-200x	VHP Stainless Steel Fitting for 1/16" OD tubing	30,000 psi (2,070 bar)		10-pk
VHP-320x	VHP Reusable Fitting for 1/16" OD tubing	25,000 psi (1,724 bar)		10-pk

## Sample Injectors

### How to Choose a Sample Injector

Table I below compares the characteristics of Rheodyne® manual sample injectors and will help you choose the most suitable model.

### Types and Capabilities

Models ending in 25 (i.e. 7725) are dual mode injectors. Dual mode injectors can use both the partial-filling and the complete-filling method for loading the sample loop (See the “Sample Loop Loading” Application Note on page 131). They are variable volume injectors because they allow the loading of various sample volumes. These dual mode injectors, also called front-loading injectors, have a needle port for loading sample built into the handle. The unique injection port design allows the tip of the needle to connect directly to the sample loop for no sample loss during loading.

Models ending in 10 (i.e. 7010) are single mode injectors. Single mode injectors use only the complete-filling method to load the sample loop. They are called fixed loop injectors as the sample loop size determines the sample volume. These injectors require a Loop Filler Port accessory (page 139), as a needle port is not built into the valve handle. There is not a direct connection between the syringe and the sample loop. Therefore, an excess of sample must be used to overfill the Loop Filler Port and completely fill the sample loop.

Models with an “i” suffix (i.e. 7725i) are identical to the models with the same numbers but the “i” designates a built-in position sensing switch. The switch provides the chromatograph with a reproducible start signal to mark the injection time in the data system.

The reproducibility of manual sample injectors depends on operator skill, syringe calibration, and the loading method. Partial-filling method is typically reproducible to 1.0% relative standard deviation (RSD). Complete-filling method is reproducible to 0.1% RSD for loops  $\geq 5 \mu\text{L}$ .

### Scale, Sample Volume, and Loop Size

Analytical scale models are for conventional columns with samples from 1.0  $\mu\text{L}$  to 5.0 mL. Microscale models are for 1.0 mm and 2.0 mm inner diameter columns. Model 8125 has a sample range of 0.1  $\mu\text{L}$  to 500  $\mu\text{L}$ , and can be used for both analytical and micro columns. Preparative scale models are for columns with diameters from 1 to 10 cm, and operate at high flow rates with samples from 100  $\mu\text{L}$  to 20 mL.

### Liquid Contact Materials

All models have a polymeric rotor seal of Vespel® (pH 0 to 10 tolerance), ETFE or PEEK™ (both pH 0 to 14). Stators are 316 stainless steel or PEEK. Most models have an inert ceramic stator face assembly.

### Make-Before-Break (MBB®)

Models incorporating Rheodyne’s MBB architecture design provide uninterrupted flow when switching between LOAD and INJECT positions. MBB greatly reduces transient pressure shocks and is beneficial for flow-sensitive detectors, fragile columns, and pumps. Models 7725, 9725, 3725, and “i” versions contain the MBB design.

### Replacement Parts

Genuine Rheodyne parts are available for easy maintenance of your Rheodyne valve. RheoBuild® Kits offer a complete solution to keep your valve running, providing all necessary parts to rebuild your valve and easy to use step by step instructions to assist you in the process. Rheodyne also offers a complete line of sample loops, fittings, and accessories designed specifically for the Rheodyne valve.

## Characteristics of Rheodyne Manual Sample Injectors

Type & Capabilities	Scale	Partial Filling Volumes (Range)	Sample Loop Sizes (Range)	Wetted Materials	Max. psi (bar) <sup>1</sup>	Max. T (°C)	MBB <sup>2</sup>	Model <sup>3</sup>
Dual Mode Can load the loop by two methods: 1) Partial filling – syringe determines volume without wasting sample 2) Complete filling – loop determines volume by over filling loop	Analytical	1 $\mu\text{L}$ – 2.5 mL	2 $\mu\text{L}$ – 5.0 mL	316 SST, Vespel	7,000 (483)	80°	Yes	7725, 7725i
		1 $\mu\text{L}$ – 5.0 mL	2 $\mu\text{L}$ – 10 mL	PEEK, ETFE, ceramic	5,000 (340)	50°	Yes	9725, 9725i
	Micro	0.1 $\mu\text{L}$ – 500 $\mu\text{L}$	5 $\mu\text{L}$ – 1.0 mL	316 SST, PEEK, Vespel, ceramic	7,000 (483)	80°	No	8125
		Preparative	100 $\mu\text{L}$ – 10 mL	2.0 mL – 20 mL	316 SST, PEEK PEEK	5,000 (340) 4,000 (276)	50° 50°	Yes Yes
Single Mode Can load the loop by one method: Complete filling – loop determines volume by over filling loop	Analytical	Not Applicable	5 $\mu\text{L}$ – 5.0 mL	316 SST, Vespel	7,000 (483)	80°	No	7000
			5 $\mu\text{L}$ – 10 mL	PEEK, ETFE, Ceramic	5,000 (340)	50°	No	9010
	Micro	Not Applicable	0.5 $\mu\text{L}$ – 5 $\mu\text{L}$ 0.2 $\mu\text{L}$ – 1 $\mu\text{L}$	316 SST, Vespel 316 SST, Vespel	7,000 (483) 7,000 (483)	80° 80°	No No	7410 7520

SST = Stainless Steel

<sup>1</sup> This is the maximum pressure to which the valve can be adjusted. Some models are shipped from the factory set for lower pressures.

<sup>2</sup> MBB (Make-Before-Break) is a design that provides uninterrupted flow when switching between LOAD and INJECT. MBB also greatly reduces transient pressure shocks.

<sup>3</sup> Models with an “i” suffix have a built-in position sensing switch. Models 8125 and 9010 also have a built-in switch.

## High Pressure Switching Valves

High pressure manual switching valves simplify procedures and improve the speed, resolution, and sensitivity of HPLC analysis. The switching valves are available in 316 stainless steel and PEEK™, with a choice of 1.6 mm (1/16") or 3.2 mm (1/8") ports. See Table on page 132 for valve specifications.

### Column Selection

The six-position switching valves are used for column selection. These valves substitute one column for another without the need to manually disconnect the plumbing. This makes it easy to designate a separate column for each analysis, which helps eliminate equilibration delays, reduce interferences and prolong column life. Turning the valve handle selects the column desired for a particular analysis. Columns switched to off-line are automatically sealed at both ends.

### Column Switching

The two-position switching valves can be used to reroute mobile phase during the chromatographic run without changing separation techniques. They can also be used to perform sequential separations with different columns and/or mobile phases.

Although the model 7000 is the most commonly used and versatile switching valve, other models have specific uses such as for three-way or four-way switching patterns.

Many models have flow passages available in both standard bore and large bore (designated with an "L" suffix). L models use 1/16" fittings and tubing but have larger flow passage diameters than non-L models. As such, L models can accommodate higher flow rates. Large bore tubing can be used when the pressure drop must be limited. Large bore valves have a lower pressure drop than standard bore valves when both valve sizes accommodate the same flow rate.

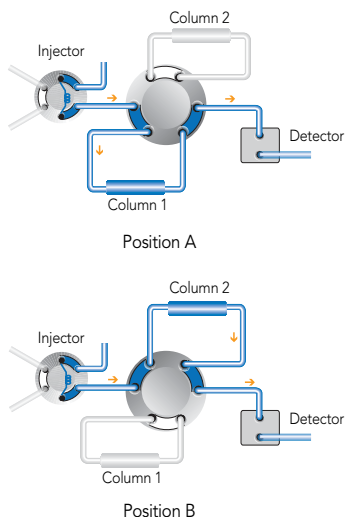

Column Selection Using a 2-Position, 6-Port Switching Valve

## Effects of Valves and Tubing on Resolution

The effect of tubing on analytical and microscale analyses can be significant. Since dispersion caused by tubing is proportional to the fourth power of diameter, large bore tubing should be avoided when performing analytical scale or microscale analyses. Tubing ID size  $\leq 0.25$  mm (0.010") is recommended.

Consider a system with injector and column switching valves and analytical columns with small-bore connecting tubing. The chromatograms below, made using a typical analytical chromatograph, show these effects. Scheme A is the control (injector  $\rightarrow$  column  $\rightarrow$  detector) with no valve in the system. In Schemes B and C, two model 7060 Six-Position Switching Valves were placed side by side (injector  $\rightarrow$  valve #1  $\rightarrow$  column  $\rightarrow$  valve #2  $\rightarrow$  detector).

The injector and detector were connected to these valves by the same tubing used in the control. The extra tubing pieces required to connect the valves to the column were a 10 cm length for valve #1-to-column, and a 35 cm length for column-to-valve #2. The diameters of these tubes are indicated in the experimental details, below.

### Comparison of Observed Column Plates of Rheodyne® Analytical and MicroScale Injectors

	7725	8125	$\Delta$
$k' = 0.6$	2930	5054	72%
$k' = 1.5$	4653	6904	48%
$k' = 7.9$	7875	8305	5.0%

UV detector: 1  $\mu$ L volume, 4 mm path. Sample volume: 2  $\mu$ L, partial-filling method.  
Column: 2 mm ID x 100 mm long, 4  $\mu$ m C-18. True plates of column = 11,570.

### Effects of Valves and Tubing on Resolution

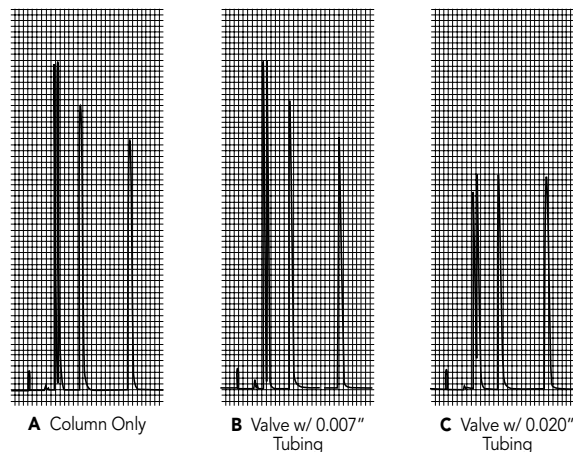

These chromatograms show the loss of resolution caused by the addition of two model 7060 column selection valves when using connection tubes of two different inside diameters. Conditions for all cases: 4.6 mm x 12.5 cm column, 5  $\mu$ m C-18 packing, 50% acetonitrile in water, 2.0 mL/min, 21 °C, 5.0  $\mu$ L sample partial filled into a model 7125 injector, 10 cm x 0.18 mm (0.007") bore injector outlet tube (to column or valve), 10 cm x 0.18 mm bore detector inlet tube (from column or valve), low dispersion 1.0 cm path UV detector cell, 0.2 sec detector time constant. See text above for details.



## Manual Injector Valves

## High Pressure Dual Mode Sample Injectors

## Models 7725(i), 9725(i), 8125, and 3725(i)-038

- ▶ 316 stainless steel
- ▶ Available in analytical, micro, and preparative scale
- ▶ Make-Before-Break (MBB<sup>®</sup>) architecture allows continuous flow between LOAD and INJECT positions which greatly reduces transient pressure shocks that disrupt your system
- ▶ Wide, 30° port angles offer easier access to fittings using the IDEX Wrench (Part No. 6810 on page 140)
- ▶ Front-end pressure screw makes it easy to adjust and maintain pressure
- ▶ A built-in position sensing switch ("i" versions) provides the chromatograph with a reproducible start signal



The MBB valve design is illustrated below. In the LOAD position, mobile phase flow from pump port to column port travels through both the rotor seal groove and the MBB passage (Position A). As the rotor seal grooves rotate to change from LOAD to INJECT, there is continuous mobile phase flow through both one rotor seal groove and the MBB passage (Position B) until the rotation stops and both rotor seal grooves are connected by the loop. Sample flow begins through the loop to the column just as all flow stops through the MBB passage (Position C). Sample flow never enters the MBB passage. Valve flow passages are 0.6 mm (0.024") in diameter.

## Make-Before-Break Design

Flow paths of model 7725(i) and 9725(i) with MBB design

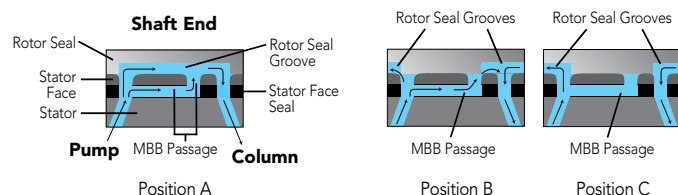

**Top Seller** SEE STARRED PRODUCTS

Part No.	Description	Pressure Rating	Sample Loop Included	Tubing/Fittings Size	Wetted Material
<b>HIGH PRESSURE MANUAL INJECTORS</b>					
3725	Preparative Scale Dual Mode Injector	4,000 psi (276 bar)	10 mL	5/16-24 ports for 1/8" Tubing	PEEK™
3725-038	Preparative Scale Dual Mode Injector	5,000 psi (345 bar)	10 mL	5/16-24 ports for 1/8" Tubing	Stainless Steel
3725i	Preparative Scale Dual Mode Injector with Switch	4,000 psi (276 bar)	10 mL	5/16-24 ports for 1/8" Tubing	PEEK
3725i-038	Preparative Scale Dual Mode Injector with Switch	5,000 psi (345 bar)	10 mL	5/16-24 ports for 1/8" Tubing	Stainless Steel
★ 7725	Analytical Scale Dual Mode Sample Injector	5,000 psi (345 bar)	20 µL	10-32 ports for 1/16" OD Tubing	Stainless Steel
★ 7725i	Analytical Scale Dual Mode Sample Injector, with Switch	5,000 psi (345 bar)	20 µL	10-32 ports for 1/16" OD Tubing	Stainless Steel
8125*	Micro Scale Dual Mode Sample Injector with Switch	5,000 psi (345 bar)	5 µL	10-32 ports for 0.020" (0.5 mm) or 1/16" Tubing	Stainless Steel
9725	Analytical Scale Dual Mode Sample Injector	5,000 psi (345 bar)	20 µL	10-32 ports for 1/16" OD Tubing	PEEK
★ 9725i	Analytical Scale Dual Mode Sample Injector with Switch	5,000 psi (345 bar)	20 µL	10-32 ports for 1/16" OD Tubing	PEEK

\*The 8125 requires special ferrules for 0.020" (0.5 mm) tubing. 8125-084 – 0.5 mm ferrule for 8125; 8125-086 – 0.5 mm ferrule for 8125 - 4-pk.

## Application Note

## Dual Mode Sample Loop Loading: Partial-Filling vs. Complete-Filling

## Partial-Filling

Use the partial-filling method if you need to conserve sample, or if you want to vary sample volume frequently.

In partial-filling, the syringe sets the volume injected onto the column. There is no sample waste, and the volume injected onto the column is equal to that dispensed from the syringe. Reproducibility is 1.0% relative standard deviation (RSD). The volume of the sample loaded is limited to half the sample loop volume. For example, the most you can load into a 200 µL sample loop is 100 µL.

## Complete-Filling

Use the complete-filling method if you have plenty of sample, if you do not vary sample volume, or if you need high reproducibility.

In complete-filling, the loop sets the volume loaded onto the column. Use excess sample (two to five loop volumes) to replace all the mobile phase in the loop. See Figure 2. Change the loop to vary the sample volume. Reproducibility is typically 0.1% RSD for loop sizes ≥ 5 µL. Accuracy is limited as loop volumes are nominal.

**Q:** "Which method should I use and which Rheodyne<sup>®</sup> sample injectors use this method?"

**A:** There are two types of injectors available: dual mode and single mode. Dual mode injectors allow both partial- and complete-filling whereas single mode injectors allow only complete-filling. See Sample Injectors on pages 129 – 132.

If you are collecting experimental data, sample is scarce, and/or you want to use different sample volumes, a dual mode injector with a large volume sample loop is appropriate. Only dual mode injectors allow the partial-filling method for easily varying your volumes (up to half your sample loop volume) by setting the syringe volume. Once you begin routine analysis, and/or you have an abundance of sample, either a dual mode or single mode injector is appropriate. Both types of injectors allow the complete-filling method in which you overfill the sample loop. Complete-filling maximizes the reproducibility of your results.

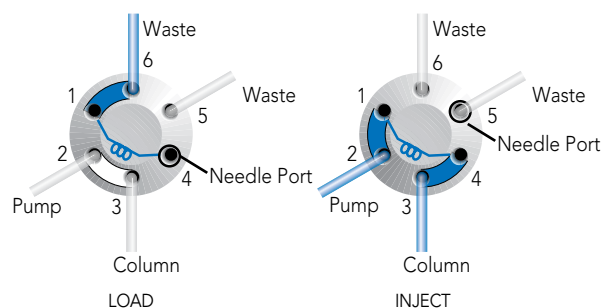

Flow path for the typical dual mode injector

## High Pressure Single Mode Injectors and Switching Valves

### Models 7000(L), 7010, 3000-038, 3000 and 9010

- ▶ Analytical and preparative scale available
- ▶ Stainless steel and PEEK™ materials
- ▶ Applicable for sample injection, column switching, and sample enrichment applications
- ▶ Field adjustable up to 7,000 psi (models 7000 and 9000 only)

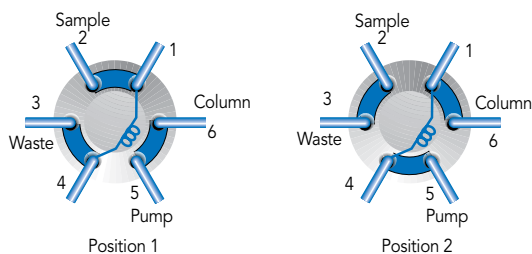

Flow path of Two-Position, Six-Port Injection Valve



### Pressure Drop vs. Flow Rate

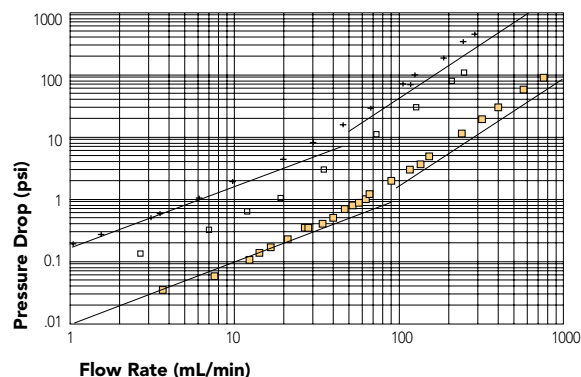

Pressure drop vs. flow rate for model 7000 and model 7000L (large-bore) valves; water at 20 °C. Experimental measurements: The flow channel is one stator inlet port, one rotor seal groove, one stator outlet port and two connecting tubes. Solid squares = (1.0 mm 7000L valve) + (two 1.0 mm x 5.0 cm tubes). Open squares = (0.6 mm 7000 valve) + (two 1.0 mm x 5.0 cm tubes). Cross mark = (0.6 mm 7000 valve) + (two 0.5 mm x 5.0 cm tubes). Solid lines are theoretical values for 10 cm long tubes of 1.0 mm and 0.5 mm ID. Pressure drop is in units of psi.

## Specifications

Model	Stator Passage Diameter	Factory Set Pressure	Maximum Field Set Pressure	Maximum Temperature (°C)
3000, 3030 (PEEK)	1.0 mm (0.040")	3,000 psi (207 bar)	4,000 psi (276 bar)	50°
3000-038	1.0 mm (0.040")	4,000 psi (276 bar)	5,000 psi (340 bar)	50°
7000, 7010	0.6 mm (0.024")	5,000 psi (340 bar)	7,000 psi (483 bar)	80°
7000L	1.0 mm (0.040")	3,000 psi (207 bar)	5,000 psi (340 bar)	80°
7060L	1.0 mm (0.040")	3,000 psi (207 bar)	5,000 psi (340 bar)	80°

SST = Stainless Steel

Part No.	Description	Tubing/Fitting Size	Wetted Material
<b>HIGH PRESSURE SINGLE MODE INJECTORS AND SWITCHING VALVES</b>			
<b>3000</b>	2-position, 6-port Switching Valve, Preparative Scale	5/16-24 Ports for 1/8" Tubing	PEEK
<b>3000-038</b>	2-position, 6-port Switching Valve, Preparative Scale	5/16-24 Ports for 1/8" Tubing	Stainless Steel
<b>7000</b>	2-position, 6-port Switching Valve, Large Bore	10-32 Ports for 1/16" OD Tubing	Stainless Steel
<b>7000L</b>	2-position, 6-port Switching Valve, Large Bore	10-32 Ports for 1/16" OD Tubing	Stainless Steel
<b>7010</b>	2-position, 6-port Single Mode Injector*	10-32 Ports for 1/16" OD Tubing	Stainless Steel
<b>9010</b>	2-position, 6-port Switching Valve Single Mode Injector*	10-32 Ports for 1/16" OD Tubing	PEEK

\*Ships with a 20 µL sample loop attached to ports 1 and 4.

## Manual Switching Valves

## High Pressure Two- and Six-Position Switching Valves

Models 7030(L), 7040(L), 7060(L), 3030-038, 9030, 9060, and 3030

- ▶ Available in 3, 4, and 6 way configurations
- ▶ Pressure rating 4,000 psi to 7,000 psi (maximum field set pressure)
- ▶ Stainless steel and PEEK™ materials
- ▶ Analytical and preparative scale available

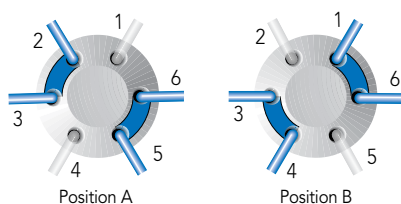

Flow path of Three-Way Switching Valve

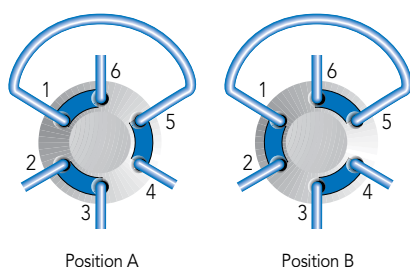

Flow diagram of a Four-Way Switching Valve

## Application Note

Six column selection using two model 7060 switching valves.

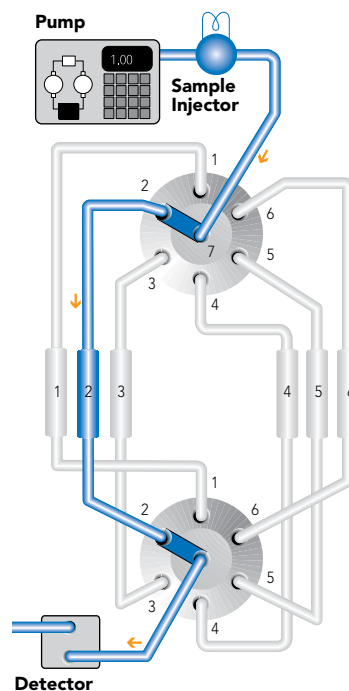

Please Note: The valves on this page ship with one set of 10-32 (1/16") or 5/16-24 (1/8") RheFlex Two-Piece Fittings. The material of these accessories match that of the stator material. Replacements and alternatives are available on pages 13 and 14.

## Specifications

Part No.	Stator Passage Diameter	Factory Set Pressure	Maximum Field Set Pressure	Maximum Temperature (°C)
3030 (PEEK)	1.0 mm (0.040")	3,000 psi (207 bar)	4,000 psi (276 bar)	50°
3030-038 (SST)	1.0 mm (0.040")	4,000 psi (276 bar)	5,000 psi (340 bar)	50°
7030, 7040 (SST)	0.6 mm (0.024")	5,000 psi (340 bar)	7,000 psi (483 bar)	80°
7030L, 7040L (SST)	1.0 mm (0.040")	3,000 psi (207 bar)	5,000 psi (340 bar)	80°
7060 (SST)	0.4 mm (0.016")	5,000 psi (340 bar)	7,000 psi (483 bar)	80°
7060L (SST)	1.0 mm (0.040")	3,000 psi (207 bar)	5,000 psi (340 bar)	80°
9030, 9060 (PEEK)	0.4 mm (0.016")	5,000 psi (340 bar)	5,000 psi (340 bar)	50°

SST = Stainless Steel

Part No.	Description	Configuration	Tubing/Fitting Size	Wetted Material
<b>HIGH PRESSURE SWITCHING VALVES</b>				
3030	2-Position, 6-Port Switching Valve, Preparative	Double 3-Way	5/16-24 ports for 1/8" OD Tubing	PEEK
3030-038	2-Position, 6-Port Switching Valve, Preparative	Double 3-Way	5/16-24 ports for 1/8" OD Tubing	Stainless Steel
7030	2-Position, 6-Port Switching Valve	Double 3-Way	10-32 ports for 1/16" OD Tubing	Stainless Steel
7030L	2-Position, 6-Port Switching Valve, Large Bore	Double 3-Way	10-32 ports for 1/16" OD Tubing	Stainless Steel
7040	2-Position, 6-Port Switching Valve, Large Bore	4-Way	10-32 ports for 1/16" OD Tubing	Stainless Steel
7040L	2-Position, 6-Port Switching Valve	4-Way	10-32 ports for 1/16" OD Tubing	Stainless Steel
7060	6-Position, 7-port, Switching Valve	6-Way	10-32 ports for 1/16" OD Tubing	Stainless Steel
7060L	6-Position, 7-Port, Switching Valve, Large Bore	6-Way	10-32 ports for 1/16" OD Tubing	Stainless Steel
9030	2-Position, 6-Port Switching Valve	Double 3-Way	10-32 ports for 1/16" OD Tubing	PEEK

## Rotor Seals and Stators

The rotor seal is the polymeric disc that makes a high pressure seal against the stator or stator face seal. The seal wears with use and is one of the only parts that may need routine replacement.

Stators are available in 316 stainless steel, PEEK™ and proprietary materials. Stators need replacement only if the ports or sealing surfaces become damaged. Avoid damage from use of improper injection needles by referring to the “Using Proper Syringe Needles” Application Note on page 139.



*Please Note: Rotor seals for MX Series II™ Modules are available in RheoBuild® Kits on page 135. Stators for MX Series II Modules are available on this page. MX (Series I) Module rotor seals are available in RheoBuild Kits on page 135. Stators are available at [www.idex-hs.com](http://www.idex-hs.com).*

### Application Note

#### How to Select the Right Rotor Seal

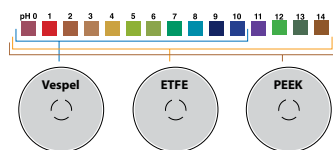

The standard rotor seal in many Rheodyne® manual valves is made from a Vespel® blend. This polyimide has low wear and high chemical resistance. Vespel tolerates a pH range of 0 to 10. Solutions more basic than pH 10 dissolve Vespel which damages the rotor seal. If you

use any solutions above pH 10, Rheodyne recommends a PEEK blend rotor seal. PEEK offers a high chemical resistance and versatility, and will tolerate the entire pH range from 0 to 14. ETFE blend rotor seals are appropriate for use in applications where PEEK is not generally acceptable, such as when methylene chloride or DMSO in higher concentrations is being used.



**Top Seller** SEE STARRED PRODUCTS

Part No.	For Valve Model No.	Description
<b>VESPEL BLEND ROTOR SEALS</b>		
7000-016	7000L, 7040L	Vespel Rotor Seal
7010-039	7010, 7000, 7040	Vespel Rotor Seal
★ 7030-003	7030	Vespel Rotor Seal
7030-014	7030L	Vespel Rotor Seal
7060-070	7060, 7066	Vespel Rotor Seal
7060-064	7060L	Vespel Rotor Seal
7125-047	7125, 7725	Vespel Rotor Seal
7410-038	7410	Vespel Rotor Seal
7413-013	7413	Vespel Rotor Seal
8125-038	8125	Vespel Rotor Seal

Part No.	For Valve Model No.	Description
<b>ETFE BLEND ROTOR SEALS</b>		
7000-017	7000L, 7040L	ETFE Rotor Seal
7010-071	7010, 7010-087, 7000, 7040	ETFE Rotor Seal
7030-015	7030	ETFE Rotor Seal
7060-074	7060, 7066, 9060	ETFE Rotor Seal
7060-067	7060L	ETFE Rotor Seal
7125-079	7125, 7125-081, 7725	ETFE Rotor Seal
7410-075	7410	ETFE Rotor Seal
8125-097	8125	ETFE Rotor Seal
9010-051	9010	ETFE Rotor Seal
9125-082	9125, 9725	ETFE Rotor Seal
<b>PEEK BLEND ROTOR SEALS</b>		
3030-005	3030, 3030-038	PEEK Rotor Seal
3710-008	3000, 3000-038, 3710, 3710-038	PEEK Rotor Seal
3725-018	3725, 3725-038	PEEK Rotor Seal
9010-065	7010, 9010	PEEK Rotor Seal
8125-119	8125	PEEK Rotor Seal
9125-095	9125, 9725	PEEK Rotor Seal
<b>STATORS FOR MX SERIES II MODULES</b>		
7123-548	MXT715-000	Stator
7123-550	MXT715-105	Stator
7123-568	MXT715-102	Stator
7770-229	MXP7920-000	Stator
7980-004	MXP7980-000	Stator
7986-004	MXP7986-000	Stator
7900-146	MXP9900-000	Stator
7900-179	MXP7900-000	Stator
7900-183	MXP7970-000	Stator
7960-014	MXP7960-000	Stator
9960-002	MXP9960-000	Stator
<b>STATORS FOR OTHER RHEODYNE VALVES</b>		
3725-006	3725, 3710-038, 3000-038 and 3030-038	Stator
3725-085	3725-038, 3710-038, 3000-038 and 3030-038	Stator
7010-069	7000L, 7030L, 7040L	Stator
7010-040	7010, 7125, 7000, 7030 and 7040	Stator
7010-066	7125-081 and 7010-087	Stator
7060-039	7060 and 7066	Stator
7060-065	7060L	Stator
7123-047	PR/EV500-100	Stator
7123-127	PR/EV750-107	Stator
7123-128	PR/EV700-107	Stator
7123-142	PR/EV500-104	Stator
7123-145	PR/EV550-104	Stator
7123-147	PR/EV550-100	Stator
7123-148	PR/EV500-101	Stator
7123-149	PR/EV550-101	Stator
7123-180	PR703-100 and EV700-105	Stator
7123-221	PR753-100 and EV750-105	Stator
7123-223	PR/EV700-112	Stator
7123-390	EV200-102	Stator
7410-041	7410 and 7413	Stator
7520-030 (inlet)	7520	Stator
7520-035 (outlet)	7520	Stator
7650-002	PR/EV700-102	Stator
7725-010	7725(i)	Stator
7750-070	7750	Stator
7750-038	PR/EV700-100	Stator
8125-098	8125	Stator
9060-016	9060	Stator
9125-043	9125, 9010, 9030 and 9725(i)	Stator
9650-009	PR/EV750-102	Stator
9750-021	PR/EV750-100	Stator

## RheBuild® Kits

RheBuild Kits are available for all Rheodyne® brand products. Included in each individualized RheBuild Kit are all parts, tools, and instructions to maintain precision performance of your particular product. RheBuild Kits eliminate individual part ordering.



### Application Note

#### How to Avoid Pressure Transients

Air in the sample loop can cause an instantaneous system pressure drop that eventually returns to a normal level. Air causes the pressure to drop when the injector moves from the LOAD to the INJECT position. When large sample loops ( $\geq 100 \mu\text{L}$ ) are partially loaded, air present in the needle port tube is pushed into the sample loop (see Figure 1). Air can also enter the sample loop from siphoning which occurs when the vent line is higher than the injection port. In either case, upon injection, the system pressure collapses the air bubble, causing pressure to drop momentarily.

A pressure drop in the system caused by air results in changes in retention time, artifact peaks, and affects column performance.

Avoid pressure drops by removing the air in the needle port tube. Do this by flushing about 1 mL of mobile phase with a luer syringe with needle port cleaner. Keep the needle port tube filled with mobile phase by occasional flushing. Adjust the vent line(s) so the outlet is at the same horizontal level as the needle port (see Figure 2). For additional injection troubleshooting, refer to the Rheodyne Troubleshooting Guide for HPLC Injection Problems. You may download the Guide from the IDEX Health & Science web site: [www.idex-hs.com](http://www.idex-hs.com) under Support.

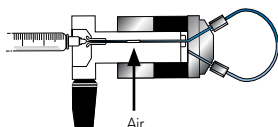

**Figure 1** Air present in the needle port tube is pushed by the syringe during loading into the sample loop

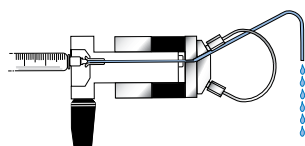

**Figure 2** Pathway of the flushing mobile phase using the Needle Port Cleaner, Part # 7125-054 (see page 139) when the injector is in INJECT

Order Online  [WWW.IDEX-HS.COM](http://www.idex-hs.com)

#### Part No. Description

##### RHEBUILD KITS FOR MX SERIES II™ VALVES

<b>7150-999</b>	RheBuild Kit for MXT715-000
<b>7152-999</b>	RheBuild Kit for MXT715-102
<b>7155-999</b>	RheBuild Kit for MXT715-105
<b>7920-999</b>	RheBuild Kit for MXP7920-000 and MXP7900-000
<b>7960-999</b>	RheBuild Kit for MXP9960-000
<b>7961-999</b>	RheBuild Kit for MXP7960-000
<b>7970-999</b>	RheBuild Kit for MXP7970-000
<b>79801-999</b>	RheBuild Kit for MXP7980-000
<b>79861-999</b>	RheBuild Kit for MXP7986-000
<b>7900-999</b>	RheBuild Kit for MXP9900-000

##### RHEBUILD KITS FOR MANUAL VALVES

<b>3725-999</b>	RheBuild Kit for models 3725, 3725i, 3725-038, 3735i-038
<b>7010-996</b>	Conversion Kit including Stator Face Assembly for model 7010
<b>7010-997</b>	RheBuild Kit including Stator for model 7010
<b>7010-999</b>	RheBuild Kit for model 7010 and 7010-type Valves
<b>7125-999</b>	RheBuild Kit for models 7125 and 7126
<b>7125TI-999</b>	RheBuild Kit for model 7125-081
<b>7410-999</b>	RheBuild Kit for model 7410
<b>7520-999</b>	RheBuild Kit for models 7520 and 7526
<b>7725-999</b>	RheBuild Kit for models 7725 and 7725i
<b>8125-999</b>	RheBuild Kit for models 8125 and 8126
<b>9010-999</b>	RheBuild Kit for model 9010
<b>9125-999</b>	RheBuild Kit for models 9125 and 9126
<b>9725-999</b>	RheBuild Kit for models 9725 and 9725i

##### RHEBUILD KITS FOR MX SERIES I™ VALVES

<b>7900-999</b>	RheBuild Kit for models MX7900-000, MX7925-000, MX9900-000, MX9925-000
<b>7960-999</b>	RheBuild Kit for model MX7960-000
<b>7980-999</b>	RheBuild Kit for model MX7980-000
<b>7984-999</b>	RheBuild Kit for model MX7984-000
<b>7986-999</b>	RheBuild Kit for model MX7986-000

##### RHEBUILD KITS FOR LABPRO™ & EV AUTOMATED FLUIDIC INSTRUMENTS

<b>1001-999</b>	RheBuild Kit for model PR100-101
<b>1005-999</b>	RheBuild Kit for model PR/EV100-105
<b>1006-999</b>	RheBuild Kit for model PR/EV100-106
<b>5001-999</b>	RheBuild Kit for models PR/EV500-101 and PR/EV550-101
<b>5100-999</b>	RheBuild Kit for models PR/EV500-100 and PR/EV550-100
<b>5104-999</b>	RheBuild Kit for models PR/EV500-104 and PR/EV550-104
<b>7004-999</b>	RheBuild Kit for models PR/EV700-104 and PR/EV750-104
<b>7112-999</b>	RheBuild Kit for models PR/EV700-112 and PR/EV750-112
<b>7501-999</b>	RheBuild Kit for models PR/EV700-100 and PR/EV750-100
<b>7502-999</b>	RheBuild Kit for models PR/EV700-102 and PR/EV750-102
<b>7507-999</b>	RheBuild Kit for models PR/EV700-107 and PR/EV750-107
<b>7531-999</b>	RheBuild Kit for models PR703-100 and PR753-100

## Stainless Steel Sample Loops

These high quality stainless steel sample loops have burr-free, square-cut ends to ensure a flush connection to valve ports. The size designations of loops are nominal. The actual volumes can differ from the theoretical designations because of the 0.001" ( $\pm 0.025$  mm) tolerance of the metal tubing bore.

Accuracy of large metal loops (1.0 mm, 0.040" bore) is about  $\pm 5\%$ , intermediate loops (0.5 mm, 0.020" bore)  $\pm 10\%$ , and small loops (0.2 mm, 0.007" bore)  $\pm 30\%$ .

Since both standards and unknowns are usually analyzed using the same sample loop, knowledge of the actual, accurate volume is rarely needed. If the sample loop volume must be known, it is best to calibrate the loop in place on the valve so the flow passages in the valve are also taken into account. An alternative to calibration is to use a dual mode injector and partial-filling method of loading. See the "Sample Loop Loading" Application Note on page 131.

Model 7725 Injector loops are not interchangeable with loops for the model 7125. The port angle for the 7725 is 30° whereas the port angle for the 7125 is 20° requiring the loops to have a different shape.

Model 8125 Micro-Scale Sample Injector requires special loops in the 5.0  $\mu\text{L}$  to 50  $\mu\text{L}$  range. The 8125 sample loops are made with 0.5 mm (0.020") OD tubing.



## Application Note

### How to Properly Install Sample Loops

#### Stainless Steel

Stainless steel sample loops are supplied with fittings that are not swaged onto the tube. It is important that the loop be completely bottomed in the injector port before the ferrule is swaged onto the tube. The depth of the tubing holes may vary slightly from port to port and from valve to valve. A fitting made up in one port may leave a small cavity in another port. The cavity causes high dispersion and peak distortion such as fronting, tailing, or broadening. It is good practice to label loop ends so they will be replaced in the same, respective ports that were used in swaging the ferrules. Hint: swaging ferrules separately on each side, into each respective valve port makes loop installation easier.

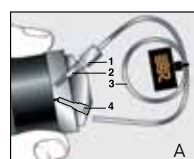

**Figure 1** Cut-away view of stainless steel sample loop installation

To install the sample loop:

- Take one end of the loop and place the nut (1) and ferrule (2) onto the tubing (3) with the threaded portion of the nut and tapered portion of the ferrule toward the end. See Figure A.
- Insert the tubing into port (4). Confirm that the tubing is bottomed in the valve port as shown in Figure A.
- While firmly pressing down on the tubing, hand-tighten the nut as tight as possible.
- With the IDEX Wrench (see pages 33 and 140), designed especially for fittings, tighten one quarter turn past finger tight. Remove the loop to confirm the ferrule is swaged onto the tube.
- Repeat steps a-d with the other end of the loop while the swaged end remains outside the valve port. See Figure B.
- Reinstall each end of the loop to their respective ports. See Figure C.

Part No.	Volume	Tubing
<b>RHEODYNE® STAINLESS STEEL LOOPS FOR MXT 715-000</b>		
<b>7755-300</b>	5 $\mu\text{L}$ Sample Loop	0.18 mm (0.007") ID x 1/16" OD
<b>7755-301</b>	10 $\mu\text{L}$ Sample Loop	0.30 mm (0.012") ID x 1/16" OD
<b>7755-302</b>	20 $\mu\text{L}$ Sample Loop	0.30 mm (0.012") ID x 1/16" OD
<b>7755-303</b>	50 $\mu\text{L}$ Sample Loop	0.51 mm (0.021") ID x 1/16" OD
<b>7755-304</b>	100 $\mu\text{L}$ Sample Loop	0.51 mm (0.021") ID x 1/16" OD
<b>RHEODYNE STAINLESS STEEL LOOPS FOR 7125, 7010 INJECTORS (DO NOT USE FOR 7725)</b>		
<b>1876</b>	10 mL Sample Loop	2.0 mm (0.080") ID x 1/8" OD
<b>1877</b>	20 mL Sample Loop	2.0 mm (0.080") ID x 1/8" OD
<b>7020</b>	5 $\mu\text{L}$ Sample Loop	0.18 mm (0.007") ID x 1/16" OD
<b>7021</b>	10 $\mu\text{L}$ Sample Loop	0.30 mm (0.012") ID x 1/16" OD
<b>7022</b>	20 $\mu\text{L}$ Sample Loop	0.51 mm (0.020") ID x 1/16" OD
<b>7023</b>	50 $\mu\text{L}$ Sample Loop	0.51 mm (0.020") ID x 1/16" OD
<b>7024</b>	100 $\mu\text{L}$ Sample Loop	0.51 mm (0.020") ID x 1/16" OD
<b>7025</b>	200 $\mu\text{L}$ Sample Loop	0.76 mm (0.030") ID x 1/16" OD
<b>7026</b>	500 $\mu\text{L}$ Sample Loop	0.76 mm (0.030") ID x 1/16" OD
<b>7027</b>	1.0 mL Sample Loop	0.76 mm (0.030") ID x 1/16" OD
<b>7028</b>	2.0 mL Sample Loop	1.0 mm (0.040") ID x 1/16" OD
<b>7029</b>	5.0 mL Sample Loop	1.0 mm (0.040") ID x 1/16" OD
<b>RHEODYNE STAINLESS STEEL LOOPS FOR 3725-038, 3725i-038 INJECTORS</b>		
<b>3065-018</b>	2.0 mL Sample Loop	2.0 mm (0.080") ID x 1/8" OD
<b>3065-019</b>	5.0 mL Sample Loop	2.0 mm (0.080") ID x 1/8" OD
<b>3065-023</b>	10 mL Sample Loop	2.0 mm (0.080") ID x 1/8" OD
<b>3065-025</b>	20 mL Sample Loop	2.0 mm (0.080") ID x 1/8" OD
<b>RHEODYNE STAINLESS STEEL LOOPS FOR 7725, 7725i, PR/EV700-100, PR/EV703-100, MX MODULE INJECTORS (DO NOT USE FOR 7125)</b>		
<b>1876</b>	10 mL Sample Loop	2.0 mm (0.080") ID x 1/8" OD
<b>1877</b>	20 mL Sample Loop	2.0 mm (0.080") ID x 1/8" OD
<b>7755-020</b>	5 $\mu\text{L}$ Sample Loop	0.18 mm (0.007") ID x 1/16" OD
<b>7755-021</b>	10 $\mu\text{L}$ Sample Loop	0.30 mm (0.012") ID x 1/16" OD
<b>7755-022</b>	20 $\mu\text{L}$ Sample Loop	0.30 mm (0.012") ID x 1/16" OD
<b>7755-023</b>	50 $\mu\text{L}$ Sample Loop	0.51 mm (0.020") ID x 1/16" OD
<b>7755-024</b>	100 $\mu\text{L}$ Sample Loop	0.51 mm (0.020") ID x 1/16" OD
<b>7755-025</b>	200 $\mu\text{L}$ Sample Loop	0.76 mm (0.030") ID x 1/16" OD
<b>7755-026</b>	500 $\mu\text{L}$ Sample Loop	0.76 mm (0.030") ID x 1/16" OD
<b>7755-027</b>	1.0 mL Sample Loop	0.76 mm (0.030") ID x 1/16" OD
<b>7755-028</b>	2.0 mL Sample Loop	1.0 mm (0.040") ID x 1/16" OD
<b>7755-029</b>	5.0 mL Sample Loop	1.0 mm (0.040") ID x 1/16" OD
<b>RHEODYNE STAINLESS STEEL LOOPS FOR 8125 INJECTOR (USE 7755-024 TO 7755-029 FOR VOLUMES &gt; 50 <math>\mu\text{L}</math>)</b>		
<b>8020</b>	5 $\mu\text{L}$ Sample Loop	0.20 mm (0.008") ID x 0.020" OD
<b>8021</b>	10 $\mu\text{L}$ Sample Loop	0.20 mm (0.008") ID x 0.020" OD
<b>8022</b>	20 $\mu\text{L}$ Sample Loop	0.25 mm (0.010") ID x 0.020" OD
<b>8023</b>	50 $\mu\text{L}$ Sample Loop	0.30 mm (0.012") ID x 0.020" OD
<b>8125-084</b>	Ferrules for 0.020" (0.5 mm) Tubing	
<b>8125-086</b>	Ferrules for 0.020" (0.5 mm) Tubing, 4-pk	

# Sample Loops

## PEEK™ Sample Loops

Flexible PEEK sample loops are alternatives to stainless steel loops. PEEK loop ends are provided with clean, straight cuts for easy valve installation.

PEEK polymer is inert to almost all organic solvents and is biocompatible, giving PEEK loops added versatility. Natural PEEK is used for these sample loops. Like metal loops, the size designations of PEEK loops are nominal. The actual volumes can differ from the theoretical designations because of the  $\pm 0.05$  mm (0.002") tolerance of the tubing bore. Accuracy of large PEEK loops (0.8 mm, 0.030" bore) is about  $\pm 14\%$ , intermediate loops (0.5 mm, 0.020")  $\pm 21\%$ , and small loops (0.2 mm, 0.007")  $\pm 65\%$ .

PEEK loops are also supplied with unswaged RheFlex fittings but do not require the same swaging precaution. The fittings can reposition along the loop tubing when the fitting reinserts in the ports for correct loop installation.

*Please Note: Several of our PEEK Sample Loops can also be used with Valco/MCI® sample injectors. Please refer to the product listing on this page to aid selection.*

## Valco/MCI-Compatible Stainless Steel Sample Loops

Valco-Compatible Stainless Steel Loops are manufactured by IDEX Health & Science. These loops are designed for use with Valco valve models CW6 and EC6W. Each loop has burr-free, polished ends and is passivated and flushed with reagent-grade methanol to ensure cleanliness.

Loops made with 1/16" OD tubing come complete with F-287 SealTight™ Fittings, which are pressure rated to 9,000 psi (620 bar)<sup>1</sup>. The fittings and adapters that accompany the 1/8" OD sample loops are rated to 1,000 psi (69 bar)<sup>1</sup>. Volumes are stated at  $\pm 10\%$ , with exact calibration services available. Each sample loop we calibrate is documented and supplied with a calibration certificate.



<sup>1</sup> These pressure ratings reflect the performance of the fittings, not the port or valve in which they are used.

IDEX Health & Science manufactures many products designed as direct replacements for OEM components. Reference to these manufacturers does not imply their endorsement of our products.

## Application Note

### PEEK Physical Strength Characteristics

Although PEEK material is compatible with virtually all solvents, there are many factors that affect burst pressure of PEEK tubing. Factors such as increases in inner diameter, temperature, exposure time, and concentration of organic solvents affect the degradation of PEEK. Other solvents such as THF, methylene chloride and DMSO cause PEEK tubing to swell while concentrated nitric acid and sulfuric acid weaken the tubing.



Part No.	Volume	Tubing	Valco No.
<b>PEEK LOOPS FOR 3725, 3725i INJECTORS</b>			
3055-018	2.0 mL Sample Loop	1.6 mm (0.062") ID x 1/8" OD	N/A
3055-019	5.0 mL Sample Loop	1.6 mm (0.062") ID x 1/8" OD	N/A
3055-023	10 mL Sample Loop	2.0 mm (0.080") ID x 1/8" OD	N/A
3055-025	20 mL Sample Loop	2.0 mm (0.080") ID x 1/8" OD	N/A
<b>PEEK LOOPS FOR 9725, 9010, PR/EV750-100, PR/EV753-100 INJECTORS</b>			
Part No.	Volume	Bore / Tubing	Valco No.
9055-020	5.0 µL Sample Loop	0.18 mm (0.007") ID x 1/16" OD	SL5CWPK
9055-021	10 µL Sample Loop	0.25 mm (0.010") ID x 1/16" OD	SL10WPK
9055-022	20 µL Sample Loop	0.25 mm (0.010") ID x 1/16" OD	SL20WPK
9055-023	50 µL Sample Loop	0.51 mm (0.020") ID x 1/16" OD	SL50WPK
9055-024	100 µL Sample Loop	0.51 mm (0.020") ID x 1/16" OD	SL100WPK
9055-025	200 µL Sample Loop	0.51 mm (0.020") ID x 1/16" OD	N/A
9055-026	500 µL Sample Loop	0.76 mm (0.030") ID x 1/16" OD	SL500WPK
9055-027	1.0 mL Sample Loop	0.76 mm (0.030") ID x 1/16" OD	SL1KCWPK
9055-028	2.0 mL Sample Loop	0.76 mm (0.030") ID x 1/16" OD	SL2KCWPK
9055-029	5.0 mL Sample Loop	0.76 mm (0.030") ID x 1/16" OD	N/A
9055-033	10 mL Sample Loop	0.76 mm (0.030") ID x 1/16" OD	N/A
<b>PEEK LOOPS FOR 7725, 7725i, PR/EV700-100</b>			
7123-227	1 µL Sample Loop (model PR/EV700-100 only)	internal groove	N/A
7755-015	2 µL Sample Loop (models 7725 and 7725i only)	internal groove	N/A
<b>REPLACEMENT RHEFLEX FITTINGS FOR PEEK LOOPS</b>			
Part No.	Description	Qty.	
6000-078	Nut/Ferrule Set, Natural PEEK, 5/16-24, for 1/8" OD loops	ea.	
6000-079	Ferrules, Natural PEEK, for 1/8" OD loops	5-pk	
6000-251	Ferrules, Natural PEEK, for 1/16" OD loops	10-pk	
6000-254	Nut/Ferrule Sets, Natural PEEK, 10-32, for 1/16" OD loops	10-pk	
<b>VALCO/MCI-COMPATIBLE STAINLESS STEEL LOOPS FOR C6W, EC6W INJECTORS</b>			
Part No.	Volume	Tubing	Valco No.
1750	5 µL Sample Loop	0.18 mm (0.007") ID x 1/16" OD	SL5CW
1751	10 µL Sample Loop	0.25 mm (0.010") ID x 1/16" OD	SL10CW
1752	15 µL Sample Loop	0.25 mm (0.010") ID x 1/16" OD	SL15CW
1755	20 µL Sample Loop	0.51 mm (0.010") ID x 1/16" OD	SL20CW
1758	25 µL Sample Loop	0.51 mm (0.010") ID x 1/16" OD	SL25CW
1759	50 µL Sample Loop	0.51 mm (0.020") ID x 1/16" OD	SL50CW
1762	100 µL Sample Loop	0.51 mm (0.020") ID x 1/16" OD	SL100CW
1778	200 µL Sample Loop	0.76 mm (0.030") ID x 1/16" OD	N/A
1763	250 µL Sample Loop	0.76 mm (0.030") ID x 1/16" OD	SL250CW
1764	500 µL Sample Loop	0.76 mm (0.030") ID x 1/16" OD	SL500CW
1770	1 mL Sample Loop	0.76 mm (0.030") ID x 1/16" OD	SL1KCW
1772	2 mL Sample Loop	1.02 mm (0.040") ID x 1/16" OD	SL2KCW
1775	5 mL Sample Loop	2.03 mm (0.080") ID x 1/8" OD	SL5KCW
1776	10 mL Sample Loop	2.03 mm (0.080") ID x 1/8" OD	SL10KCW

## Application Note

## Fluidic Movement in Tubes

**Q:** "Why can I load only up to half of the volume of the loop in partial-filling method?"

**A:** Sample occupies 2  $\mu\text{L}$  of loop for every 1  $\mu\text{L}$  loaded from the syringe. For example, 10  $\mu\text{L}$  of sample spreads out over the entire length of a 20  $\mu\text{L}$  loop. Any additional sample loaded will overflow the end of the loop and exit out to waste. Reproducibility is poor because the volume of sample in the loop is different from the known volume originally loaded by your syringe.

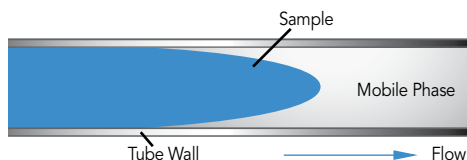

**Figure 1** Schematic of sample flow through mobile phase between tubing walls

Fluid spreads in a parabolic shape through a tube instead of moving in one plug because the velocity is different at the center of the tube than at the walls. The velocity at the center of the tube is twice the average velocity, and near the wall the velocity is almost zero, creating a parabolic shape. This fluidic movement is called laminar flow. See Figure 1.

In dual mode injectors (see "Sample Loop Loading" Application Note on page 131) the sample from the syringe needle loads directly into the sample loop. The sample volume is known since there is no sample waste. The laminar flow phenomenon accounts for the shape of the plot as shown in Figure 2. Note that the plot has three regions:

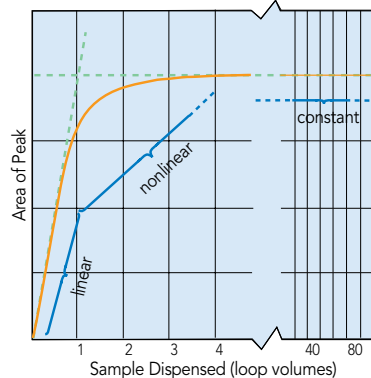

**Figure 2** Sample mass (observed peak area) vs. volume of sample dispensed from the syringe, in units of loop volumes, injected onto the column from a Rheodyne® dual mode injector such as model 7725

a) Partial-Filling Region. When the volume dispensed is less than half the loop volume, the curve is linear. Sample has not reached the end of the loop. Within this region, performance depends on the syringe and operator.

b) Nonlinear Region. When the volume dispensed is between half the loop volume and about two loop volumes, the curve is nonlinear. Sample is lost from the loop, so reproducibility is poor. If you dispense a volume equal to the loop size, you are in this region of poor performance.

c) Complete-Filling Region. When the volume of sample dispensed is several loop volumes, the loop contains only pure sample, undiluted by residual mobile phase. Within this region, reproducibility is highest.

In the single mode injectors the sample must pass through a connecting passage before it reaches the sample loop. Since some of the sample dispensed from the syringe remains in the connecting passageway, an unknown amount enters the sample loop. Therefore, single mode injectors achieve high reproducibility only by using the complete-filling method.

## Application Note

## How to Find and Fix Common Sample Injector Leaks

Leaks cause valuable sample loss. Nobody wants that. The key to the valve holding pressure is the integrity of the sealing surfaces. If there is a scratch on the sealing surface, or the needle seal in the rotor seal is damaged, a leak may appear. It is also important to realize what appears to be a leak can instead be a result of siphoning. The following are the three most common situations in which fluid leaks occur.

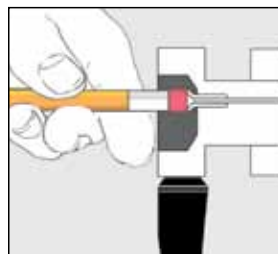

**Figure 1** To reform the needle seal, push the eraser end of a pencil against the needle port

1. If fluid leaks out of the needle port only while loading the loop (i.e., while pushing down on the plunger of the syringe), the problem is most likely that the needle seal or the needle port fitting in the loop filler port is not gripping the syringe needle tightly enough. Tighten the needle seal grip by pushing with the eraser end of the pencil on the needle port (See Figure 1). The tightening reduces the hole diameter of the needle seal and port fitting.

2. If fluid leaks continuously from the needle port or vent lines and/or from the stator-to-stator ring interface, replace the rotor seal and/or stator face assembly. Scratches on the rotor seal or cracks in the stator face assembly allow mobile phase to escape and cause cross port leakage. Genuine Rheodyne replacement rotor seals are listed on page 134.

3. If fluid leaks from the needle port and/or vent lines but eventually stops, the cause is most likely siphoning and not a leak. Siphoning occurs if the vent lines are lower or higher than the needle port. Adjust the vent line(s) so that the outlet is at the same horizontal level as the needle port to prevent siphoning. (See Figure 2).

For other leakage or injection troubleshooting, refer to the Rheodyne Troubleshooting Guide for HPLC Injection Problems. You may download the Guide from the Rheodyne web site: [www.idex-hs.com](http://www.idex-hs.com) under Support.

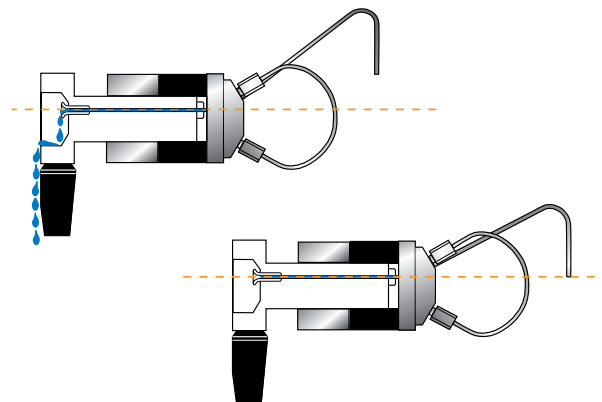

**Figure 2** Needle port level compared to the level of vent line outlet: (A) siphoning occurs when the vent line outlet is above the needle port level (B) siphoning does not occur if the vent line outlet is the same horizontal level as the needle port



## Adapters for Syringe Needles

## Application Note

## Using Proper Syringe Needles

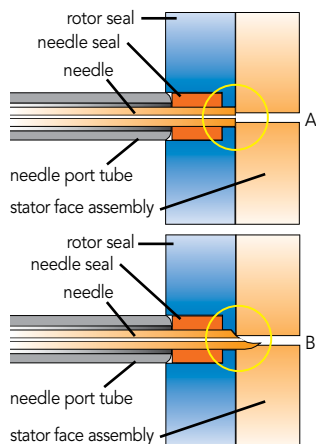

**Figure 1** A square cut needle: (A) stops against the stator face assembly; The tip of a pointed needle (B) slips into the stator face and the tip breaks off as the valve rotates

With front-loading injectors it is important to use the correct needle when loading the sample loop. An incorrect needle will damage the valve and can cause poor reproducibility. When the needle is too short the tip will not reach the needle seal. When the needle is too small in diameter the seal will not grip tightly enough. Needles with a beveled tip can damage the rotor seal and stator face assembly (see Figure 1). The needle should be #22 gauge (0.028" – 0.0285" / 0.72 mm), and 90° point style (square cut end). Model 3725 requires a #16 gauge (0.0645" – 0.0655" / 1.65 mm) needle. NEVER USE A BEVELED, POINTED, OR TAPERED NEEDLE.

Needle specifications are not critical when using a Loop Filler Port to load the sample loop. However, it is important to tighten the needle port fitting around the needle if using a syringe needle with a slightly smaller diameter than 0.7 mm (0.028").

If the loading method used is complete-filling, a syringe without a needle can be used. A syringe fitted with a Needle Port Cleaner (Figure 2A) or with a front-loading valve (Figure 2B).

Needle port accessories are listed on this page.

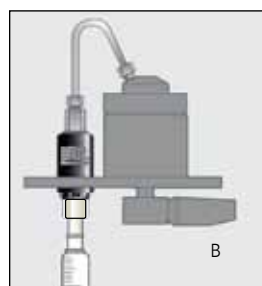

**Figure 2**  
(A) Syringe fitted with Needle Port Cleaner (Part # 7125-054) loading a front-loading valve (model 7725)  
(B) loading a Loop Filler Port (Part # 7012)

## Needle Port Accessories

The Rheodyne® adaptable Loop Filler Ports (Part #7012 and 9012) are used to load sample from syringe needles or luer tips. The Needle Port (Part #9013) conserves sample by minimizing the volume between the needle and the valve.

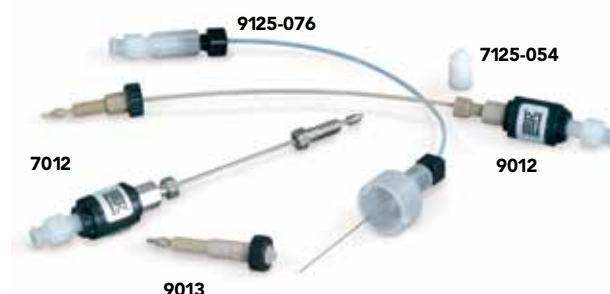

## Valve Adapter for 10-32 Ports

- ▶ For 1/32" OD stainless steel tubing
- ▶ Low swept volume
- ▶ Extends the life of the rotor

As a result of customer requests, a Valve Adapter for 10-32 ports was designed specifically for use with 1/32" OD stainless steel tubing. This product extends the life of and prevents damage to the rotor, guarding against such potential hazards as tubing that may pass through the stator and scratch the rotor. This adapter has a very low swept volume, at 300 nL. The all-PEEK™ fluid pathway ensures biocompatibility.

**M-400**

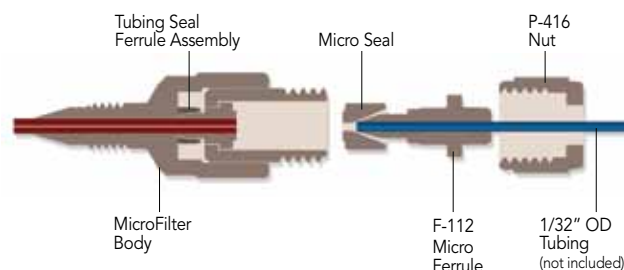

**M-400**  
Valve Adapter  
(Includes indicated products)

Part No.	Description
<b>NEEDLE PORT ACCESSORIES</b>	
7012	Stainless Steel Loop Filler Port
7125-054	Needle Port Cleaner
9012	PEEK Loop Filler Port
9013	PEEK Needle Port
9125-076	Suction Needle Adapter (for Model 9725)
<b>VALVE ADAPTER FOR 10-32 PORTS</b>	
F-112	Replacement MicroFerrule for M-400, Natural PEEK
M-400	Valve Adapter Assembly
P-416	Replacement Female Nut for M-400, Natural PEEK

### Micro Injection Port Adapters

- ▶ For 1/32" or 360 µm OD tubing
- ▶ Mount on actuator, bracket or bulkhead

To introduce sample, connect 1/32" or 360 µm OD capillary tubing to an Upchurch Scientific® Injection Port Adapter Assembly. These adapters accept standard 22 gauge Hamilton-style injection syringe needles. No additional swept volume is added to the fluid pathway by these adapters, as the needle butts directly against the connecting tubing during injections. The adapters can be bulkhead mounted or mounted with the V-447 Kits. Refer to the chart below to select the appropriate adapter assembly.

To introduce a sample directly into a 10-32 port, purchase a M-432-03 separately.

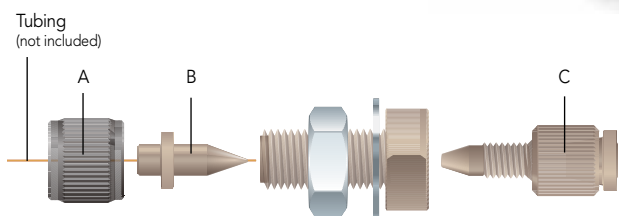

**M-432**  
Micro Injection Port Adapter Assembly

### Medium Pressure Injection Port Adapter

This simple, biocompatible adapter is designed specifically for the Medium Pressure Injection Valves on page 142 and can also convert any 1/4-28 flat-bottom port into a port that can accept a standard 22 gauge HPLC injection needle. This injection port adapter is adjustable, so you can create a snug fit around the needle to prevent any leaking of the analyte. In addition, this product features an internal stop that prevents you from inserting the needle too far, eliminating the possibility of damaging the valve with the needle tip.

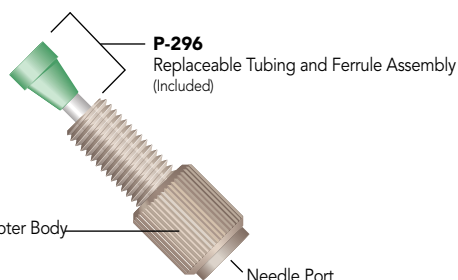

**P-295**  
Medium Pressure Injection Port Adapter

### Mounting Brackets

Rheodyne® mounting brackets and panels of different shapes and sizes organize and provide a sturdy support for Rheodyne valves. The Ring Stand Mounting Bracket now allows the valves to mount onto common laboratory equipment.



### Replacement Parts

	A	B	C
<b>For 1/32" OD Tubing</b>			
M-433	P-416	F-112	M-432-03
<b>For 360 µm OD Tubing</b>			
M-432 and V-447	P-416BLK	F-152	M-432-03

*\*See diagram above*

### IDEX Wrench

The smartly designed IDEX Wrench is a double-ended slotted socket wrench that fits over 1/16" and 1/8" OD tubing. It easily loosens and tightens 1/4" and 5/16" hex head stainless steel or PEEK™ fittings. The "Z" shape of the IDEX Wrench provides ideal leverage for changing sample loops and fittings, and keeps one end from restricting the use of the other.



Part No.	Description
<b>MICRO INJECTION PORT ADAPTERS</b>	
<b>For 1/32" OD Tubing</b>	
F-112	Replacement MicroFerrule for M-433, Natural PEEK
M-433	Micro Injection Port Adapter Assembly
M-432-03	Replacement Tubing/Fitting Assembly for M-432 & M-433
P-416	Replacement Female Nut for M-433, Natural PEEK
<b>For 360 µm OD Tubing</b>	
F-152	Replacement MicroFerrule for M-432, Natural PEEK
M-432	Micro Injection Port Adapter Assembly
M-432-03	Replacement Tubing/Fitting Assembly for M-432 & M-433
P-416BLK	Replacement Female Nut for M-432, Black PEEK
V-447	Micro Injection Port Adapter Assembly Actuator Mounting Kit Includes (1) M-432 with mini-actuator bracket and (2) mounting screws
<b>IDEX WRENCH</b>	
6810	IDEX Wrench
<b>MOUNTING BRACKET ACCESSORIES</b>	
7160	Mounting Panel
7160-010	Valve Angle Bracket
7160-029	Ring Stand Mounting Bracket
<b>MEDIUM PRESSURE INJECTION PORT ADAPTER</b>	
P-295	Adjustable Injection Port Adapter
P-296	Replacement Tubing/Ferrule Assembly

## Low Pressure Valves

## MXX Low Pressure Valves

- ▶ Switching and selection valve models
- ▶ Can withstand up to 125 psi (9 bar)
- ▶ Proprietary polymer combination allows interface for long life
- ▶ All models accept 1/16" or 1/8" tubing (proper ferrules required)

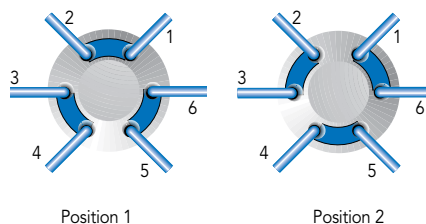

Flow Path of MX Series II™, Two-Position, Six-Port Switching Valve

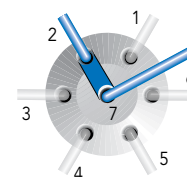

Flow path of MX Series II Six-Position, Seven-Port Selector Valve



CE

## Specifications

<b>Flow Passages</b>	0.41 mm (0.016") – 1.5 mm (0.060") diameter
<b>Power Requirements</b>	100-120 V <sub>AC</sub> , 50-60 Hz
<b>Regulatory Compliance</b>	CE Mark
<b>Remote Control</b>	USB, I <sup>2</sup> C, BCD, Level Logic
<b>Operating Temperature</b>	0° – 40 °C, non-condensing
<b>Storage Temperature</b>	0° – 75 °C
<b>Dimensions ( H x W x D )</b>	117 mm x 76 mm x 128 mm (4.6" x 3.0" x 5.0")

Part No.	Description	Pressure Rating	Ferrule Size	Tubing/Fittings Size	Wetted Material
<b>MXX LOW PRESSURE VALVES</b>					
<b>MXX777-601</b>	2-position, 6-port, Switching Valve	125 psi (8.5 bar)	1/16"	Accepts Either 1/16" or 1/8" Tubing	RPC-7*
<b>MXX777-603</b>	2-position, Double Three Way	125 psi (8.5 bar)	1/16"	Accepts Either 1/16" or 1/8" Tubing	RPC-7
<b>MXX777-605</b>	6-position, 7-port, Selection Valve	125 psi (8.5 bar)	1/16"	Accepts Either 1/16" or 1/8" Tubing	RPC-7
<b>MXX777-612</b>	2-Position, 6-Port, Large Bore Switching Valve	125 psi (8.5 bar)	1/8"	Accepts Either 1/16" or 1/8" Tubing	RPC-7
<b>MXX777-616</b>	6-position, 7-port, Large Bore Selection Valve	125 psi (8.5 bar)	1/8"	Accepts Either 1/16" or 1/8" Tubing	RPC-7
<b>MXX778-605</b>	10-position, 11-port, Selection Valve	125 psi (8.5 bar)	1/16"	Accepts Either 1/16" or 1/8" Tubing	RPC-7
<b>REPLACEMENT FITTINGS</b>					
<b>7770-039</b>	Ferrules for 1/8" OD Tubing	—	—	—	25-pk
<b>7770-040</b>	Ferrules for 1/8" Tubing	—	—	—	50-pk
<b>7770-041</b>	Ferrules for 1/8" Tubing	—	—	—	100-pk
<b>7770-044</b>	Ferrules for 1/16" OD Tubing	—	—	—	25-pk
<b>7770-045</b>	Ferrules for 1/16" Tubing	—	—	—	50-pk
<b>7770-046</b>	Ferrules for 1/16" Tubing	—	—	—	100-pk
<b>7770-124</b>	O-rings for 1/16" OD Tubing	—	—	—	25-pk

\*RPC-7 Proprietary Polymer Combination

## Medium Pressure Injection Valves

- ▶ Biocompatible and inert
- ▶ Low swept volume
- ▶ Pressure rated to 500 psi (34 bar), ceramic version and 1,000 psi (69 bar), polymer version

The Upchurch Scientific® 6-Port Medium Pressure Injection Valves feature easy, external sample loop customization. Simply clean-cut a piece of tubing that represents the volume of sample you wish to inject, taking into account the port-to-port volume of the valve. Please refer to the "Tubing Internal Diameters and Volumes" chart on page 198 for assistance in calculating the volume of a length of tubing.

Two biocompatible injection valve options are available:

### Long-Life Ceramic

Featuring ceramic-to-ceramic sealing surfaces, these long-life valves have been tested to over one million actuations with no change in performance.\* The wetted materials are chemically resistant ceramic and PEEK™ polymer and the valves are rated to 500 psi (34 bar). Each valve includes 1/4-28 Flangeless Fittings for 1/16" OD tubing.

### Economical Polymer

These economical valves have chemically resistant Vespel® and PTFE resin wetted surfaces and are rated for a maximum pressure of 1,000 psi (69 bar). Each valve includes 1/4-28 Flangeless Fittings for 1/16" or 1/8" OD tubing.

Both valve options are available in three configurations: standard manual, bulkhead mountable manual and actuated. Valves can be premounted on a DC gear motor actuator to automate valve positioning. Each actuated valve is provided with an inline power adapter which allows operation from 110/120V and 220/240V AC power, a RS-232 and contact closure communication cable and a cable for multiplexing valves in series.

\* Tested using room-temperature water as the solvent

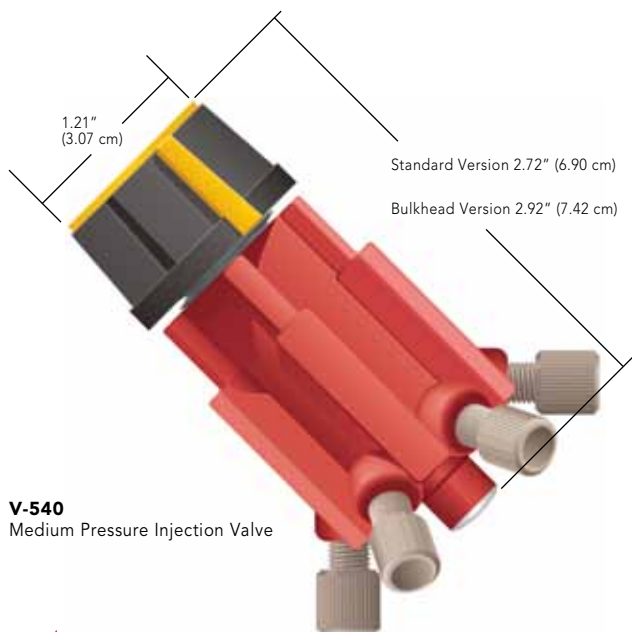

**Top Seller** SEE STARRED PRODUCTS



## Specifications

Valve Part No.	Thru-Hole	Dimensions (L x W), excluding fittings	Port to Port Volume
M-460	0.040" (1.0 mm)	2.75" x 1.30" (69.8 x 33.0 mm)	16.9 µL
M-461	0.040" (1.0 mm)	3.00" x 1.30" (76.2 x 33.0 mm)	16.9 µL
V-450	0.040" (1.0 mm)	2.72" x 1.24" (69.1 x 31.5 mm)	5.1 µL
V-540	0.063" (1.6 mm)	2.72" x 1.24" (69.1 x 31.5 mm)	12.7 µL
V-451	0.040" (1.0 mm)	2.92" x 1.24" (74.2 x 31.5 mm)	5.1 µL
V-541	0.063" (1.6 mm)	2.92" x 1.24" (74.2 x 31.5 mm)	12.7 µL

<sup>1</sup> Width of the knob, which is slightly wider than the valve body

### Viewpoint from Rotary Knob

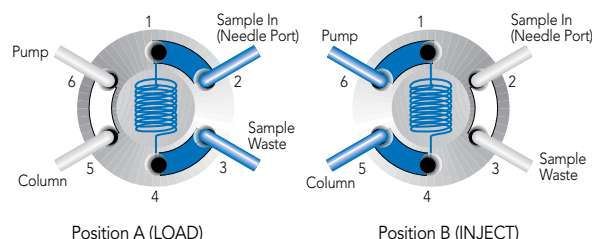

**Flow Path of Medium Pressure Injection Valve**  
(highlighting flow through sample loop in each position)

Part No.	Description	Wetted Material	Tubing OD	Includes
<b>MEDIUM PRESSURE INJECTION VALVES, MANUAL</b>				
M-460	Injection Valve	Ceramic	1/16"	(6) XP-235
★ M-461	Bulkhead version of M-460	Ceramic	1/16"	(6) XP-235
V-104	5/64" Allen Wrench (replacement)			
V-450	Injection Valve	Polymer	1/16"	(6) XP-235
★ V-451	Bulkhead version of V-450	Polymer	1/16"	(6) XP-235
V-540	Injection Valve	Polymer	1/8"	(6) XP-335
★ V-541	Bulkhead version of V-540	Polymer	1/8"	(6) XP-335
<b>MEDIUM PRESSURE INJECTION VALVES, ACTUATED</b>				
★ V-1451-DC	Actuated version of V-451, DC Gear Motor (premounted)			
V-1461-DC	Actuated version of M-461, DC Gear Motor (premounted)			
V-1541-DC	Actuated version of V-541, DC Gear Motor (premounted)			

# Medium Pressure Selection Valves

## Medium Pressure 6-Way Selection Valves

- ▶ Biocompatible and inert
- ▶ Low swept volume
- ▶ Excellent choice for mobile phase selection

The Upchurch Scientific® 6-Way Medium Pressure Selection Valves have a common inlet (or outlet) port connected to six different ports.

Two biocompatible selection valve options are available. For more information on the Long-Life Ceramic and Economical Polymer valves, please see the previous page.

If your application does not require all six outer ports, seal the extra port(s) with any flat-bottom 1/4-28 plug from page 32.

Both valve options are available in three configurations: standard manual, bulkhead mountable manual and actuated. A valve mounting bracket (M-615-2) is listed on page 144. Valves can be premounted on a DC gear motor actuator to automate valve positioning. Each actuated valve is provided with an inline power adapter which allows operation from 110/120V and 220/240V AC power, a RS-232 and contact closure communication cable and a cable for multiplexing valves in series.



## Application Note

Use our 6-Way Medium Pressure Selection Valve to easily select different solvents with an isocratic pump. The setup below involves an isocratic pump used for two separate assays, each requiring a pre-rinsing step prior to use. Using our Selection Valve in this setup, the system can be primed with the solvent in the first reservoir. Then, solvent from the second reservoir can be used as the mobile phase for the first application. Later, the system can be rinsed with an intermediate buffer solution from the third reservoir, followed by switching over to the second mobile phase in reservoir number 4. At the end of the day, the system can be rinsed with water from a fifth reservoir to avoid the possibility of precipitation on wetted surfaces. Follow this rinse with a final rinse of methanol from the sixth reservoir for system storage.

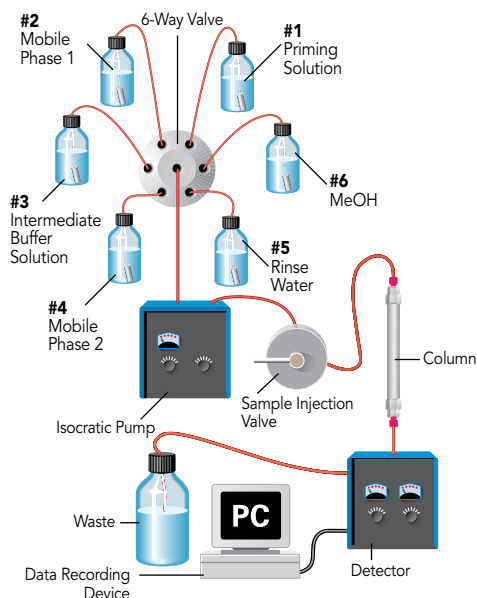

## Specifications

Valve Part No.	Thru-Hole	Dimensions (L x W), excluding fittings	Port to Port Volume
M-470	0.040" (1.0 mm)	2.75" x 1.30" (69.8 x 33.0 mm)	16.1 µL
M-471	0.040" (1.0 mm)	3.00" x 1.30" (76.2 x 33.0 mm)	16.1 µL
V-240	0.040" (1.0 mm)	2.72" x 1.24" <sup>1</sup> (69.1 x 31.5 mm)	16.1 µL
V-241	0.040" (1.0 mm)	2.72" x 1.24" <sup>1</sup> (69.1 x 31.5 mm)	16.1 µL
V-340	0.063" (1.6 mm)	2.92" x 1.24" <sup>1</sup> (74.2 x 31.5 mm)	18.1 µL
V-341	0.063" (1.6 mm)	2.92" x 1.24" <sup>1</sup> (74.2 x 31.5 mm)	18.1 µL

<sup>1</sup> Width of the knob, which is slightly wider than the valve body



**Top Seller** SEE STARRED PRODUCTS

Part No.	Description	Wetted Material	Tubing OD	Includes
<b>MEDIUM PRESSURE 6-WAY SELECTION VALVES, MANUAL</b>				
<b>M-470</b>	6-Way Selection Valve	Ceramic	1/16"	(6) XP-235
★ <b>M-471</b>	Bulkhead version of M-470	Ceramic	1/16"	(6) XP-235
<b>V-104</b>	5/64" Allen Wrench (replacement)			
<b>V-240</b>	6-Way Selection Valve	Polymer	1/16"	(6) XP-235
★ <b>V-241</b>	Bulkhead version of V-240	Polymer	1/16"	(6) XP-235
<b>V-340</b>	6-Way Selection Valve	Polymer	1/8"	(6) XP-335
★ <b>V-341</b>	Bulkhead version of V-340	Polymer	1/8"	(6) XP-335
<b>MEDIUM PRESSURE 6-WAY SELECTION VALVES, ACTUATED</b>				
★ <b>V-1241-DC</b>	Actuated version of V-241, DC Gear (premounted)			
<b>V-1341-DC</b>	Actuated version of V-341, DC Gear (premounted)			
★ <b>V-1471-DC</b>	Actuated version of V-471, DC Gear (premounted)			

## Medium Pressure 4-Port Switching Valves

- ▶ Three flow configurations to choose from
- ▶ Biocompatible flow paths, PEEK™ and PTFE
- ▶ Pressure rated to 500 psi (34 bar)

With three versions to choose from, Upchurch Scientific® Switching Valves offer several flow distribution options. Each V-100 Series Switching Valve has 0.040" (1.0 mm) thru-holes and is supplied with Flangeless Fittings for use with 1/16" OD tubing.

Each 4-Port Switching Valve is available in standard manual and bulkhead mountable manual configurations. The bulkhead mountable manual configuration can be mounted on the M-615-1 Valve Bracket (see below). DC gear motor actuated versions are also available for automated valve positioning. Each actuated valve is provided with an inline power adapter which allows operation from 110/120V and 220/240V AC power, a RS-232 and contact closure communication cable and a cable for multiplexing valves in series.

## Valve Mounting Brackets

Mount the bulkhead mountable manual valves with these Brackets. Once mounted, a valve will be positioned horizontally. Extra holes are provided for valve accessories.

Made of sturdy anodized aluminum, these brackets can be attached to almost any lab surface. Each bracket comes with the required valve mounting hardware and instructions.

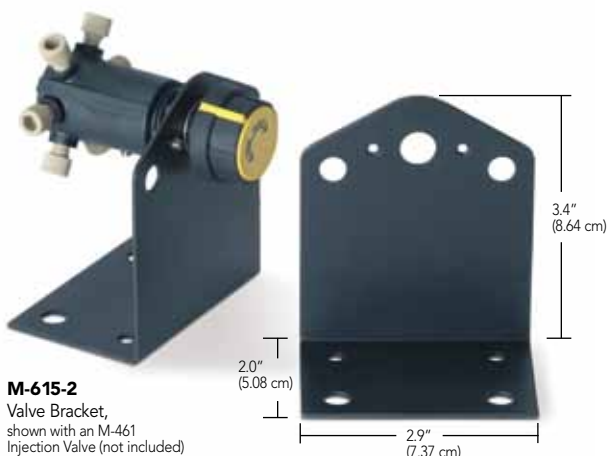

**M-615-2**  
Valve Bracket,  
shown with an M-461  
Injection Valve (not included)



**V-1101D-DC**

**V-101L**

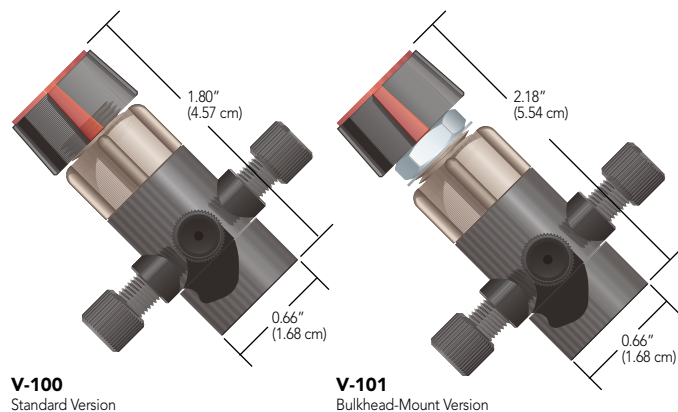

**V-100**  
Standard Version

**V-101**  
Bulkhead-Mount Version

## Related Products

To use these valves with 1/8" OD tubing, simply replace the supplied fittings with 1/4-28 Flangeless Fittings found on pages 24 – 27. *Please Note: To operate, all ports must be either connected to a line of your system or plugged. Comes complete with P-218BLK/P-240 Flangeless Fittings. "L" and "T" valve versions also include a P-309 Plug.*



**Top Seller** SEE STARRED PRODUCTS

## Switching Valve Options

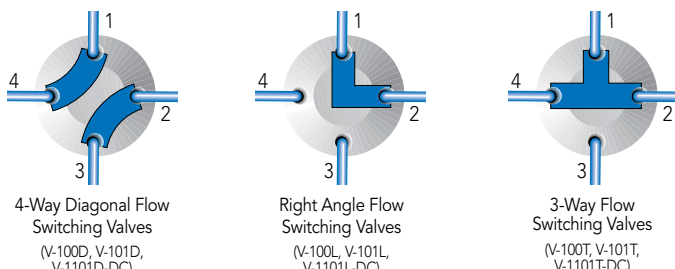

**4-Way Diagonal Flow Switching Valves**  
(V-100D, V-101D, V-1101D-DC)

**Right Angle Flow Switching Valves**  
(V-100L, V-101L, V-1101L-DC)

**3-Way Flow Switching Valves**  
(V-100T, V-101T, V-1101T-DC)

Part No.	Description	Swept Volume
<b>MEDIUM PRESSURE 4-PORT SWITCHING VALVES, MANUAL</b>		
<b>V-100D</b>	4-Way Diagonal Flow Switching Valve	12.4 µL
★ <b>V-100L</b>	Right Angle Flow Switching Valve	6.2 µL
<b>V-100T</b>	3-Way Flow Switching Valve	9.7 µL
★ <b>V-101D</b>	Bulkhead Version of V-100D	12.4 µL
★ <b>V-101L</b>	Bulkhead Version of V-100L	6.2 µL
<b>V-101T</b>	Bulkhead Version of V-100T	9.7 µL
<b>V-103</b>	0.050" Allen Wrench (replacement)	
<b>MEDIUM PRESSURE 4-PORT SWITCHING VALVES, ACTUATED</b>		
<b>V-1101D-DC</b>	Actuated Version of V-101D	12.4 µL
★ <b>V-1101L-DC</b>	Actuated Version of V-101L	6.2 µL
<b>V-1101T-DC</b>	Actuated Version of V-101T	9.7 µL
<b>VALVE BRACKET</b>		
<b>M-615-1</b>	Mounting Bracket for Switching Valves (page 144)	
<b>M-615-2</b>	Mounting Bracket for Injection and Selection Valves (this page)	

# Switching and Shut-Off Valves

## Application Note

### Medium Pressure Switching Valve Applications

Protect sensitive system components (such as a column) during a cleaning cycle with our Diagonal Flow Switching Valve ("D"). This valve eliminates the need to remove, plug and reconnect a low pressure column (see below).

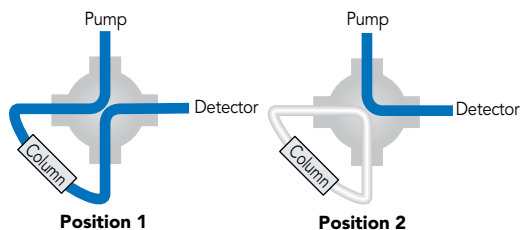

► A typical application for a Right Angle Flow Switching Valve ("L") is column switching, allowing two columns to use one detector. Detector switching is another common application for this valve (see below). Plug off the extra port with the included plug.

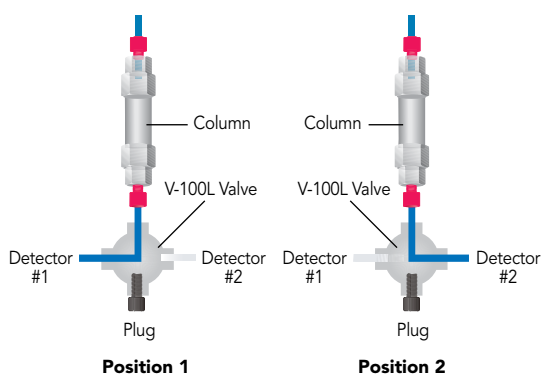

► Your detector switching application may require the flexibility of routing the column effluent to both detectors simultaneously while retaining the ability to isolate each detector. Use our 3-Way Flow Switching Valve ("T"), plugging off the fourth port with the included plug (see right).

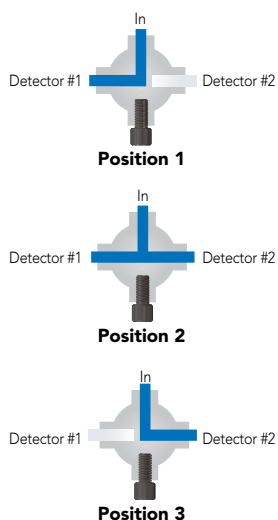

## Shut-Off Valves

- For low and medium pressure applications
- Biocompatible, all-polymer flow path
- Available for 1/16" and 1/8" OD tubing
- Pressure rated to 500 psi (34 bar)

Stop a flow stream quickly with Upchurch Scientific® biocompatible Shut-Off Valves. The bodies are manufactured from either PEEK™ or ETFE, and both versions feature a PCTFE rotor, making them highly resistant to chemical attack. The blue colorant used in some valve configurations has proven not to leach out with common HPLC solvents.

Connect semi-rigid or rigid tubing, such as PEEK, stainless steel or fluoropolymer, with the 1/4-28 Flangeless Fittings provided. Soft tubing, such as PharMed® or Tygon® (see pages 75 – 89), may be connected to these valves using our 1/4-28 barbed adapters, found on page 58.

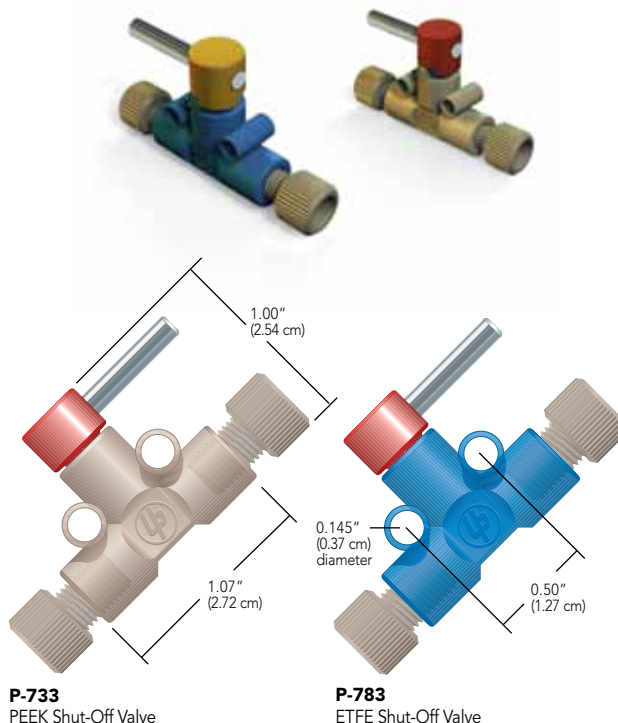

**P-733**  
PEEK Shut-Off Valve

**P-783**  
ETFE Shut-Off Valve

## Application Note

Install a Shut-Off Valve between the solvent reservoir and pump. Then, when it is necessary to disconnect the solvent line, a simple twist of the valve lever eliminates the potential of a hazardous spill.

Part No.	Material	OD Tubing	Thru-hole	Internal Volume*	Includes
<b>SHUT-OFF VALVES</b>					
P-721	ETFE, Natural	1/8"	0.040" (1.0 mm)	10.0 µL	(2) P-335, (2) P-300N
★ P-732	PEEK, Natural	1/16"	0.020" (0.5 mm)	2.5 µL	(2) XP-235
★ P-733	PEEK, Natural	1/8"	0.040" (1.0 mm)	10.0 µL	(2) XP-335
★ P-782	ETFE, Blue	1/16"	0.020" (0.5 mm)	2.5 µL	(2) XP-235
★ P-783	ETFE, Blue	1/8"	0.040" (1.0 mm)	10.0 µL	(2) XP-335

\* Maximum internal volume, with valve fully open



## Micro-Splitter Valves

- ▶ For interfacing LC-MS systems
- ▶ Adjustable split stream flow rates
- ▶ Medium and high pressure versions

The Upchurch Scientific® line of Micro-Splitter Valves is designed to accurately split and control a low-flow stream off a single incoming supply.

Choose between 1/4-28 flat-bottom and 10-32 coned threaded versions. A valve is also available to accommodate applications involving capillary tubing with a 6-32 coned threaded fitting for MicroTight® tubing sleeves (see page 19).

The High Pressure Micro-Splitter Valves are designed to operate successfully up to 4,000 psi (276 bar) and the medium pressure Micro-Splitter valves are pressure rated to 800 psi (55 bar).

Graduated Valves offer many of the benefits and features of Micro-Splitter Valves, plus the ability to adjust and set the split flow to repeatable settings. This allows documentation of settings and the resulting flow rates for easier method development. The graduations also make it easier to employ the valve in a system used to run multiple analyses that require different split flow rates. Choose from regular High Pressure and Capillary versions.

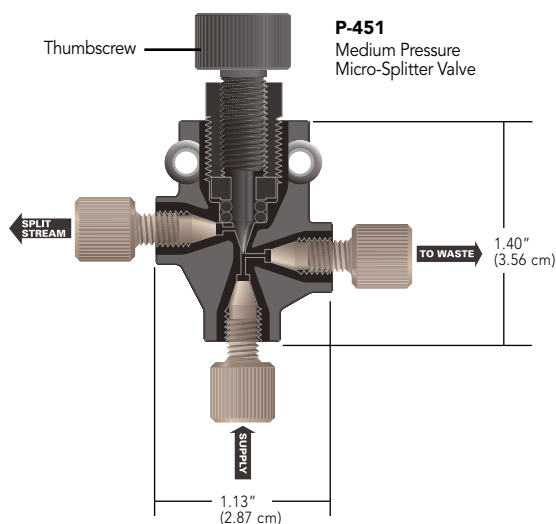

## Application Note

- ▶ With an incoming flow rate of 1mL/min using room temperature water and equal pressures on both outlet lines, the minimum split flow rate is 2 µL/min for the medium pressure micro-splitter valves and 4.8 µL/min for the high pressure micro-splitter valves.
- ▶ All Micro-Splitter Valves have been tested at flow rates to 100 mL/min, with a maximum resulting pressure drop of only 45 psi (3.1 bar) when the valve is fully opened.



**Top Seller** SEE STARRED PRODUCTS

## Specifications

Part No.	Valve Type	Threads	Internal Volume <sup>1</sup> (closed/fully open)	Max. Operating Pressure
<b>M-4055,T</b>	High Pres. Capillary	10-32 / 6-32	1.2 / 2.4 µL	4,000 psi (276 bar)
<b>M-472</b>	High Pres. Cap. Grad.	10-32 / 6-32	1.2 / 2.4 µL	4,000 psi (276 bar)
<b>P-450</b>	Medium Pressure	1/4-28	2.1 / 4.1 µL	800 psi (55 bar)
<b>P-451</b>	Medium Pressure	10-32	1.2 / 2.8 µL	800 psi (55 bar)
<b>P-452</b>	Medium Pres. Capillary	10-32 / 6-32	1.2 / 2.4 µL	800 psi (55 bar)
<b>P-460S,T</b>	High Pressure	10-32	1.2 / 2.8 µL	4,000 psi (276 bar)
<b>P-470</b>	High Pres. Graduated	10-32	1.2 / 2.8 µL	4,000 psi (276 bar)

<sup>1</sup> The supply and waste port thru-holes have IDs of 0.020" (0.50 mm). The ID for the split-stream port thru-hole is 0.020" (0.50 mm) in standard versions; in capillary versions it is 0.010" (0.25 mm).

Part No.	Description	Includes
<b>MICRO-SPLITTER VALVES</b>		
<b>P-450</b>	Medium Pressure, 1/4-28, Biocompatible	(3) XP-235
<b>P-451</b>	Medium Pressure, 10-32, Biocompatible	(3) F-120
<b>P-460S</b>	High Pressure, 10-32, with Stainless Steel Needle	(3) F-120
<b>P-460T</b>	High Pressure, 10-32, with Titanium Needle	(3) F-120
<b>GRADUATED MICRO-SPLITTER VALVES</b>		
<b>M-472</b>	High Pressure Capillary Graduated, 10-32/6-32, with Stainless Steel Needle	(2) F-120, (1) F-125*
★ <b>P-470</b>	High Pressure Graduated, 10-32, with Stainless Steel Needle	(3) F-120

\* Use with the MicroTight Tubing Sleeves, found on page 19



## Application Note

### Back Pressure Considerations

The Micro-Splitter Valves are designed to work when both effluent flow path pressures are nearly identical. However, the split flow path will often have higher back pressure than the waste flow path, making it hard to achieve any split flow at all. There are two possible solutions. Place a back pressure regulator (see pages 152–153) on the waste flow path that is equal to or slightly greater than the pressure on the split flow path. Or, switch the two effluent pathways such that the split flow pathway is attached to the “waste” port on the valve and the waste flow pathway is attached to the “split” port on the valve. (Please Note: This second method may result in a loss of adjustment sensitivity.)

### Prime/Purge Valve

Air within the pump head can cause noisy pump operation and flow instability. Solve this problem by placing a High Pressure Micro-Splitter Valve (page 146) inline between the pump and the injector valve. You can then safely divert pump flow to a waste container at a sufficient rate to dislodge the air. Remove air from the solvent line leading to the pump with a Low Pressure Prime/Purge Valve (page 155).

### Multi-Column and Detector Systems

Does your work require analyses with multiple columns and detectors that use the same mobile phase? If so, install one of our High Pressure Micro-Splitter Valves after your injector. A single injection can then be split to two separate columns and detector systems, at two different flow rates. This economical set-up eliminates the need for an additional pump and injector valve, while allowing data to be obtained simultaneously.

### Post-Detector Interfacing

Use a Medium Pressure Micro-Splitter Valve to route fluid exiting an initial detector to other devices, such as a mass spectrometer and a fraction collector. The valve will split and reduce the flow rate to that required for MS interfacing, while diverting the remainder of the flow to the collector (a back pressure regulator may also be required for this set up, available on pages 152 – 153).

### Other Applications

These valves are also suited for other applications, such as adapting a standard HPLC system to handle microbore analyses. For more information and plumbing diagrams for this application and those listed above, please contact your local distributor or IDEX Health & Science directly.

## Micro-Metering Valves

- ▶ Flow rates as low as 3.5  $\mu\text{L}/\text{min}^*$
- ▶ 1/4-28 flat-bottom and 10-32 coned designs available
- ▶ Materials of construction: PEEK™, PTFE

For fine control of fluid flow rates, Micro-Metering Valves can reduce outgoing flow to as low as 3.5  $\mu\text{L}/\text{min}^*$ . These needle valves are perfect for use with peristaltic pump fluid-transfer applications, mass spectrometry, and fraction collection.

Upchurch Scientific® Micro-Metering Valves can also be used to regulate gas flow in helium sparging lines and as a flow-dependent variable back pressure regulator. For flow independent regulation of back pressure, please see pages 152 – 153.

Flow path materials are PEEK polymer and PTFE. All versions of this valve have 0.020" (0.50 mm) thru-holes.

*\*At 1.0 mL/min incoming flow rate with room temperature water*

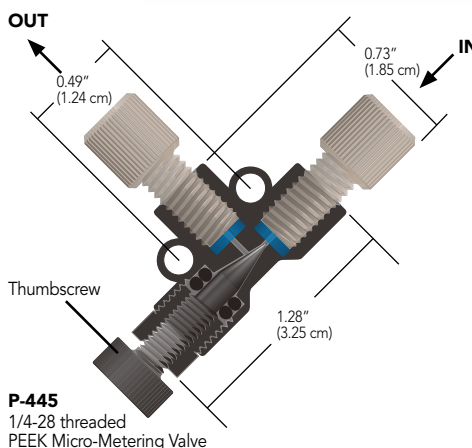

**Top Seller** SEE STARRED PRODUCTS

Part No.	Material	OD Tubing	Thru-hole	Internal Volume*	Includes
<b>MICRO-METERING VALVES</b>					
P-445	PEEK, Black	1/16"	0.020" (0.50 mm)	7.7 $\mu\text{L}$	(2) XP-230
★ P-446	PEEK, Black	1/16"	0.020" (0.50 mm)	7.2 $\mu\text{L}$	(2) F-120
P-447	PEEK, Black	1/8"	0.020" (0.50 mm)	7.7 $\mu\text{L}$	(2) XP-330

\*Maximum internal volume, with valve fully open

Order Online  [WWW.IDEX-HS.COM](http://WWW.IDEX-HS.COM)